

RENAULT CONVERSIONS



1st April 2022



Renault Conversions: Tailor-Made solutions for your business

Different chassis, still the same robustness of a Renault Master. Our Chassis Cabs and Platform Cabs are based on the Renault Master and can accommodate a wide range of conversions to meet your needs. There is a wide variety of choice from Gross Vehicle Weights, lengths, engines and the option of front wheel drive, single or double rear wheel drive giving you maximum control in the day-to-day. We offer tailor-made solutions to your individual requirements.

We also offer conversions as E-Tech electric vehicles.



Front-wheel drive



Rear-wheel drive

Drive anywhere, with various versions available

Master has two technical choices to meet your requirements:

A front-wheel drive version and a rear-wheel drive version. Master front-wheel drive* and its 3 different lengths is perfect for payload and road transport. Master rear-wheel drive is capable of transporting the heaviest loads on the rear axle (in particular with twin wheels) and towing a trailer up to 3.5 t**.

To meet occasional demands for enhanced traction Renault has developed new technology: Grip Xtend. This improves the adaptability of your vehicle on difficult roads, such as unpaved or muddy tracks. The onboard computer recovers data from the wheels to optimise the vehicle's performance.

Master 4x4 (developed with Oberaigner) is there to help you. With its raised ground clearance and differential locking, difficult conditions will no longer prevent you from working.

In 2-wheel drive mode, it has an automatic rear differential lock and gearing down can be activated. It can also be activated in full 4-wheel drive mode with a front differential lock. Master 4x4 also includes metal plate protection under the engine and under the body to protect vital components ***

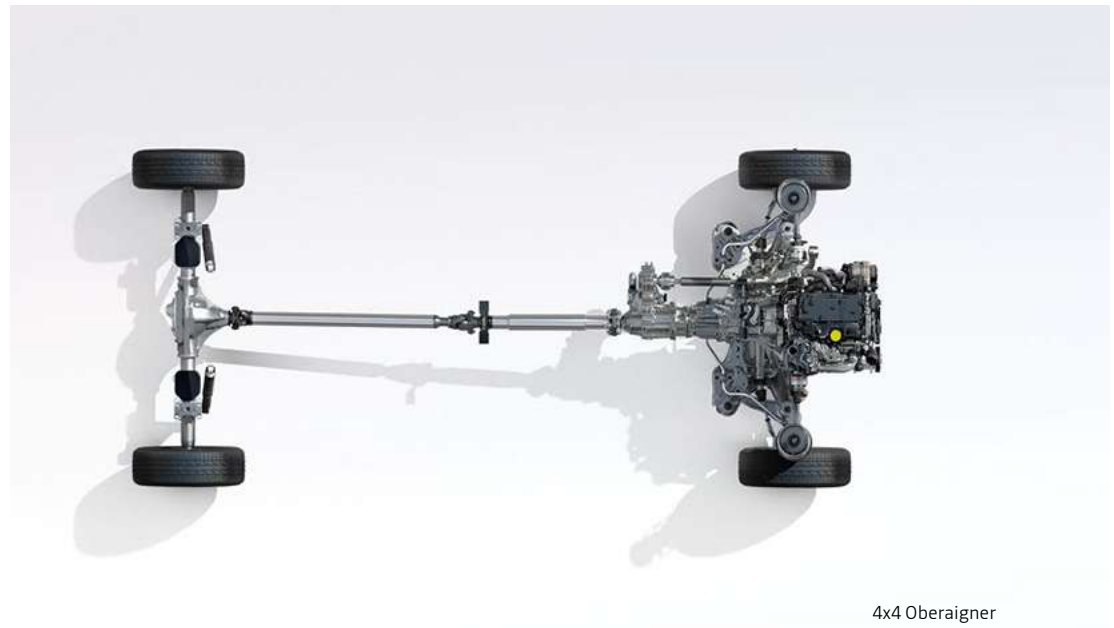
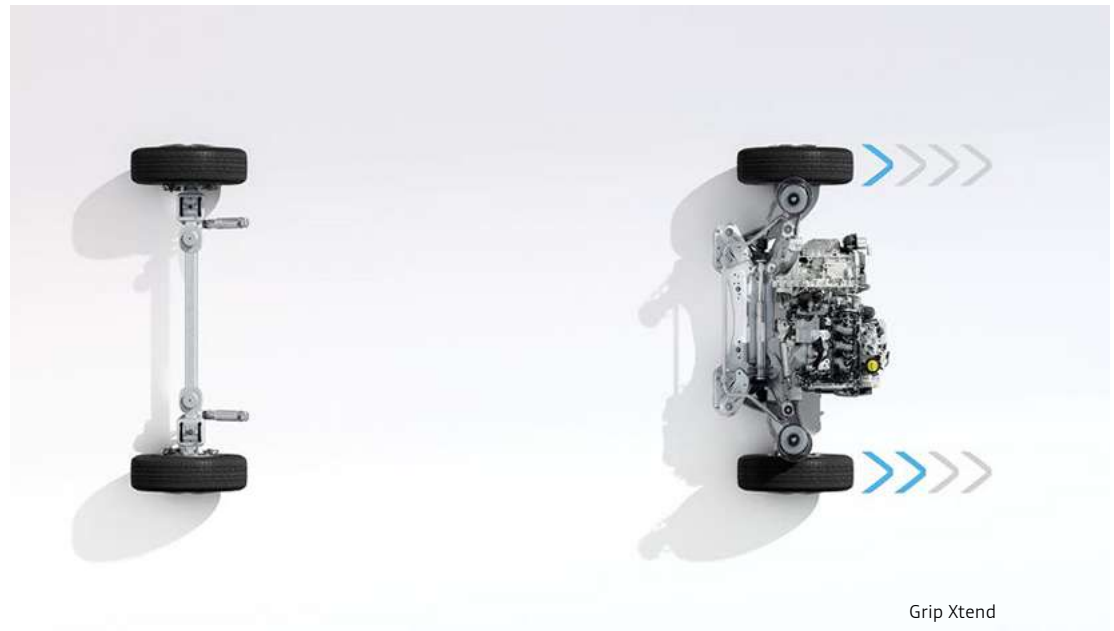

* GVW up to 3.5 t.

** Twin wheel rear-wheel drive chassis version.

*** Optional on RWD versions

Cutting emissions and your costs

Master E-Tech electric has ultra low running costs, zero emissions whilst driving and a 75 mile (WLTP^{***}) range. This gives a real-world driving range of 75 miles in summer and 50 miles in winter thanks to its lithium-ion E.V. 33 (33kWh) battery. The 57kW power unit offers a torque of 225 Nm. The E-Tech electric versions maintain the same dimensions as their diesel equivalents! The Master E-Tech electric has an impressive load capacity of up to 19m³[^] and a payload that goes up to 1,425kg, plus all the extra benefits of owning an electric vehicle. Reduced road noise, no congestion charges* and low running costs from less than 7p per mile** all prove that our Master E-Tech electric will not only be a great purchase for your fleet but also for your pocket!

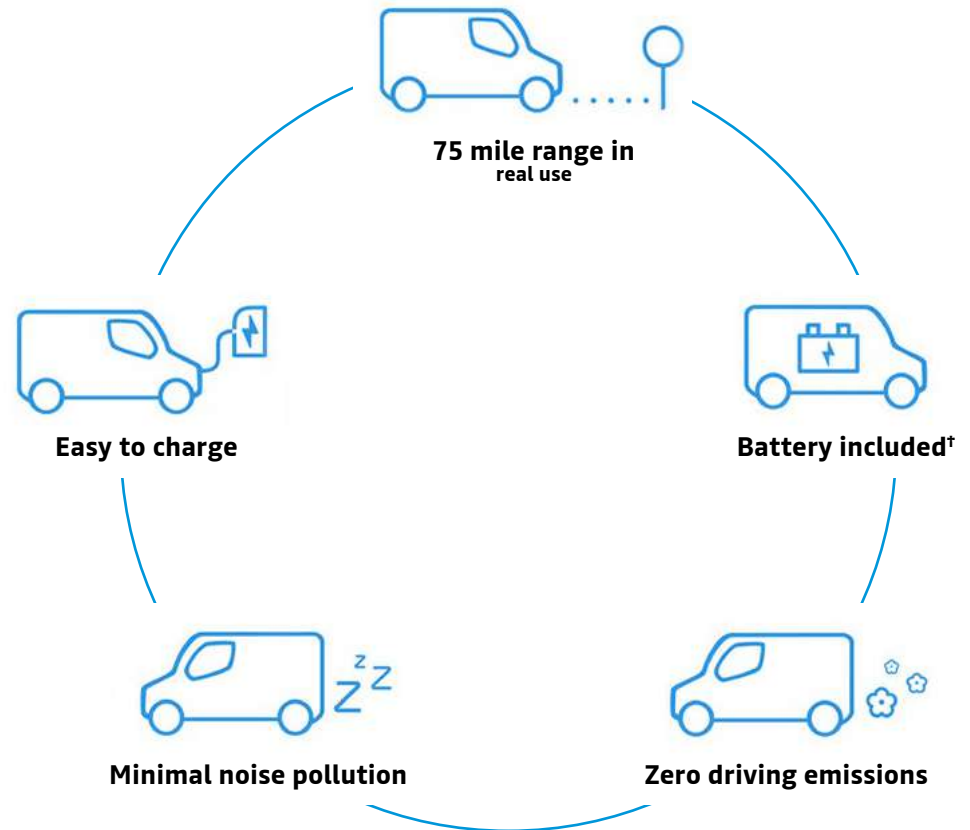

* Emission based congestion charges in ULEZ's including London Congestion Charge as of 2020. **Less than 7p per mile calculated by full recharge of 33kWh battery based on 6 hours of 14.4p per kWh (Source: UK Power) giving £4.75 full recharge cost divided by the real world summer range in miles. ***WLTP figures shown are for comparability purposes; only compare figures with vehicles tested to the same technical procedures. The WLTP electric range shown has been achieved using the new (WLTP) test procedure. Figures obtained after the battery was fully charged. Actual real world driving results may vary depending on factors such as the starting charge of the battery, accessories fitted after registration, weather conditions, driving styles and vehicle load. Renault estimates average real world driving figures for this vehicle as 75 miles in summer and 50 miles in winter, depending on the factors above.

[^] Load volume dependent on conversion.

1. Regenerative braking. The battery recharges when you take your foot off the accelerator or when you press on the brake pedal.

2. Low consumption tyres. Their low rolling resistance contributes to conserving your driving range without degrading your road-holding or braking ability.

3. Eco mode. When you activate this, you reduce the power output of the vehicle so that you can travel further (less abrupt acceleration and maximum speed of 50 mph).

4. 7 kW charger. Recharge the battery in just 6 hours with a 32 A/7 kW Wallbox. The recharging flap located on the right-hand side of the cab, is easily accessible.

[†]Battery guarantee of 5 years / 62,000 miles, whichever comes first, this includes the battery performance guarantee to at least 70% of its original capacity.

Driving range

Master E-Tech electric is now available with the E.V. battery giving a WLTP* range of 95 (city cycle) miles on one charge, meaning range anxiety is a thing of the past. With real life estimates of 75 miles in summer and 50 miles in winter**.

WLTP range* combined cycle (miles)	WLTP range* city cycle (miles)	Summer (+20°C)	Winter** (-5°C)	Cost in pence p/per mile [†]	Cost per full recharge [†]
75	95	75	50	Less than 7p	Less than £5

*What is WLTP and why the real-life range is similar to it?

Worldwide Harmonized Light Vehicles Test Procedures (WLTP), this new homologation protocol gives fuel consumption and driving range results that are much closer to real life conditions figures than the NEDC protocol. While the old NEDC test determined test values based on a theoretical driving profile, the WLTP cycle was developed using real-driving data, gathered from around the world. WLTP therefore better represents everyday driving profiles.

**Why is the range reduced in winter?

Like all batteries, those in E-Tech electric vehicles are less efficient in cold weather than at warmer ambient temperatures. This means that you can expect a reduction in the range of your Master E-Tech electric in the winter. Also, in winter you are more likely to use the heating, which means Master E-Tech electric consumes more energy.

Charging solutions – options that suit your needs!

We offer you several charging solutions to make sure your vehicle is always ready to go!

Type of charger	Where to use it	Power required	Charging times (0-100%)	
Home (3-pin plug cable)*	Home / Office	2.3kW/10A	17 hours	Occasional slow charging. *Requires additional purchase of a EVSE cable.
	Home / Office	3.3kW/14A	12 hours	
Wallbox / Public charging point	Home / Office / On the go	3.7kW/14A	11 hours	Leaving the Master to charge overnight on a 3.7kW charger ensures that it will be ready for when you to begin your next day.
	Home / Office / On the go	7kW	6 hours	
Public charging point	On the go	22kW	6 hours	A standard charging time of 6 hours means your vehicle is ready to go when you are.
	On the go	43kW	6 hours	

[†]Less than £5 full recharge cost based on 6 hours of 14.4p per kWh (Source: UK Power) Full recharge of the 33 kWh battery.

(1) For illustration purposes only, may not reflect real-life journeys.

Introducing the Renault 'Off-the-shelf' range

Our comprehensive range of 'Off-the-shelf' factory converted products are available directly from our dealer network as a 'one-stop-shop'. These vehicles are provided with a full manufacturer warranty (3 years, 100,000 miles) from Renault that applies to both the base vehicle and the conversion, giving the peace of mind you would expect when buying directly from Renault.

Our 'Off-the-shelf' factory Tipper, Dropside and Box Vans are constructed on a Chassis Cab and our Luton Low Loader is based on a Platform Cab, for a lower load height. On many of our Conversions, Single Cab, Crew Cab and Crew van versions are also available, so you don't need to choose between your tools and your crew.

Low Loader also available as an E-Tech electric vehicle.



Off-the-Shelf: Renault Master Dropside

The new Renault Master Dropside is designed to allow you to load and unload large items easily thanks to its 400mm high aluminium folding side panels. It benefits from a load length up to 4,300mm and payload[^] up to 1,399 kg.

- 3 load lengths: Medium (ML), Long (LL) and extra long (LLL) wheelbases
- Engines available: Blue dCi 130 & Blue dCi 145
- FWD or RWD, also available as a twin-wheel RWD for even more traction (ideal for towing)
- Also available as crew cab (double cab)
- Payload[^] up to 1,399 kg

Features:

- Rear corner pillars as standard
- Version available with a tail lift as standard (Del 500kg mesh platform tail lift with 915mm platform and fixed leading edge)
- Foldaway step on rear side panel
- Anchorage points in loading area (6 to 8 depending on version)
- Hot-galvanised steel front side panel and platform
- Anti-slip wooden floor
- Folding and removable aluminium side and rear panels (400mm high)
- Steel cab protecting grid with ladder/long object rack
- Additional options available on request via VFS



VFS

Contact: sales@vfs.co.uk

Tel: 023 80 613 612



[^]Payload equals the Maximum Operating Mass (Gross Vehicle Mass or GVW) less the Kerb Weight. Kerb Weight is the weight of the complete vehicle including coolant, oil, a 90% full fuel tank, a 100% full AdBlue tank, spare wheel and jack, but excluding driver and crew. All Kerb Weights, and therefore Payloads quoted are subject to a 5% manufacturing tolerance and are based on the base level model. Any additional equipment added (options or accessories), or the selection of a higher trim level, could result in a higher Kerb Weight and a reduced Payload, and may increase CO₂ and decrease MPG figures.



Off-the-Shelf: Renault Master Tipper

Renault Master Tipper benefits from a high strength steel body, resulting in a highly durable vehicle, with a payload[^] up to 1,217kg for the FWD and 1,104kg for the RWD versions. Renault Master Tipper also has excellent towing capacity with the twin wheel RWD versions being able to tow up to 3,000kg while keeping the interior comfort of a Renault Master.

- 3 load lengths : Medium (ML), (MLL) and long (LL) wheelbases
- Engines available: Blue dCi 130 & Blue dCi 145
- FWD or RWD, also available as a twin-wheel RWD for even more traction (ideal for towing)
- Also available as crew cab (double cab)
- Payload[^] up to 1,217kg

Features:

- Rear tipping 'Scattolini' body (45°)
- Hot-galvanised steel loading deck (2mm thick)
- Aluminium side and rear panels (400mm high)
- Aluminium cab protecting grid with ladder/long object rack



[^]Payload equals the Maximum Operating Mass (Gross Vehicle Mass or GVW) less the Kerb Weight. Kerb Weight is the weight of the complete vehicle including coolant, oil, a 90% full fuel tank, a 100% full AdBlue tank, spare wheel and jack, but excluding driver and crew. All Kerb Weights, and therefore Payloads quoted are subject to a 5% manufacturing tolerance and are based on the base level model. Any additional equipment added (options or accessories), or the selection of a higher trim level, could result in a higher Kerb Weight and a reduced Payload, and may increase CO₂ and decrease MPG figures.



MASTER

Off-the-Shelf: Renault Master Aluminium Tipper

The Renault Master Aluminium Tipper benefits from a high-strength, light-weight aluminium body, resulting in a highly durable vehicle, with a much improved payload[^] up to 1,314 kg for the FWD versions. Offering exactly the same high levels of testing and warranty as the steel body tipper. It is available as a Single or Double Cab and either FWD or RWD, it also has a towing capacity of up to 3,000kg.

- 2 load lengths: Medium (ML) and long (LL) wheelbases
- Engines available: Blue dCi 130 & Blue dCi 145
- Single or Double Cab
- Payload[^] up to 1,314 kg

Features:

- Tipper sub-frame manufactured from aluminium, constructed using 'state-of-the-art' robotic aluminium spot and TiG welding
- Cab protector
- Additional options available on request via VFS



VFS

Contact: sales@vfs.co.uk

Tel: 023 80 613 612



[^]Payload equals the Maximum Operating Mass (Gross Vehicle Mass or GVW) less the Kerb Weight. Kerb Weight is the weight of the complete vehicle including coolant, oil, a 90% full fuel tank, a 100% full AdBlue tank, spare wheel and jack, but excluding driver and crew. All Kerb Weights, and therefore Payloads quoted are subject to a 5% manufacturing tolerance and are based on the base level model. Any additional equipment added (options or accessories), or the selection of a higher trim level, could result in a higher Kerb Weight and a reduced Payload, and may increase CO₂ and decrease MPG figures.





Off-the-Shelf: Renault Master Luton Box Van

With a load volume of up to 20m³ and payload[^] up to 1,204kg, the Renault MASTER Luton Box Van allows the efficient enclosed transport of merchandise or objects in an optimised loading area thanks to a perfectly flat rectangular floor without wheel arches and large side walls. This vehicle is ideally suited to delivery and removal companies as well as for use as short term rental vehicles.

- Long (LL) wheelbase
- Engines available: Blue dCi 130 & Blue dCi 145
- Available in both FWD and RWD (ideal for towing)
- Payload[^] up to 1,204kg

Features:

- 11 mm thick GRP side panels, with fibreglass roof skin on a 65 mm alloy frame
- 15 mm thick wisdeck birch floor
- Luton front providing over-the-cab storage fitted as standard
- Rear doors - roller shutter on alloy frame with rear columns designed to support column mounted tail-lift
- Pull out rear step
- Additional options available on request via Truckcraft Bodies
- Version available with a tail lift as standard (Del 500kg column tail lift with 815mm alloy platform and fixed leading edge one-two button external control)



Tel: 0161 304 9404

Email: admin@truckcraftbodies.co.uk

[^]Payload equals the Maximum Operating Mass (Gross Vehicle Mass or GVW) less the Kerb Weight. Kerb Weight is the weight of the complete vehicle including coolant, oil, a 90% full fuel tank, a 100% full AdBlue tank, spare wheel and jack, but excluding driver and crew. All Kerb Weights, and therefore Payloads quoted are subject to a 5% manufacturing tolerance and are based on the base level model. Any additional equipment added (options or accessories), or the selection of a higher trim level, could result in a higher Kerb Weight and a reduced Payload, and may increase CO₂ and decrease MPG figures.





Off-the-Shelf: Renault Master Low Loader

Based on the Renault Master FWD Platform Cab, the Luton Low Loader has a loading height of 500mm to facilitate easy loading and unloading, a payload[^] of up to 1,238kg and 19m³ load volume, which make it particularly suited to removals, home delivery, as well as multiple delivery and collections.

In addition, the Low Loader's adaptability means it can be easily converted for specialist uses such as catering vehicles, mobile shop or showroom.

- Long (LL) wheelbase
- Engine available: Blue dCi 145
- 2 E-Tech electric versions
- Payload[^] of up to : 1238kg
- 19m³ of load volume
- 270 degree barn doors
- Fixed rear step
- PIR interior lighting

Also available as a fully electric version



Tel: 0161 304 9404

Email: admin@truckcraftbodies.co.uk

[^]Payload equals the Maximum Operating Mass (Gross Vehicle Mass or GVW) less the Kerb Weight. Kerb Weight is the weight of the complete vehicle including coolant, oil, a 90% full fuel tank, a 100% full AdBlue tank, spare wheel and jack, but excluding driver and crew. All Kerb Weights, and therefore Payloads quoted are subject to a 5% manufacturing tolerance and are based on the base level model. Any additional equipment added (options or accessories), or the selection of a higher trim level, could result in a higher Kerb Weight and a reduced Payload, and may increase CO₂ and decrease MPG figures.





EMERGENCY DOOR

PULL TO OPEN

62
MPH

MASTER

RENAULT

TP 68 PSI

PULL TO OPEN

PULL TO OPEN

DIESEL
BUSINESS

Tailor-Made CONVERSIONS

Renault has developed a range of Tailor-Made accredited Conversions providing popular specialist vehicle adaptations such as refrigerated vans and grounds maintenance vehicles. Our accredited range has been developed in partnership with converters who have received Renault approval after being assessed on their technical and quality standards by a dedicated team from Renault. A list of these can be found at www.conversions.renault.co.uk

Our accredited converters can also produce completely bespoke vehicles built to meet a customer's specific requirements. Our accredited converters receive specialist support and backup, ensuring that the quality of the conversion meets Renault's technical and legal requirements. Regular assessments and quality training are provided to the converters to ensure that these high standards are maintained both in the build of the vehicle and the aftersales backup provided. Renault takes responsibility for the base vehicle, and the converter is responsible for all aspects of the conversion, and in most cases the conversion will match the base vehicle warranty.* Renault, along with its dealers and accredited converters welcome any opportunity to provide bespoke solutions – contact your local dealer to discuss your specific requirements. Further assistance is also available by contacting the Converter Hotline on 0800 040 7343 or e-mail conversions@renault.co.uk

*Some exceptions apply (please check with your supplying dealer for the converter warranty statement)





MASTER

Renault Tech Parcel Van

The Renault Master Parcel Van is built to accommodate a wide range of logistics operations. Its impressive design provides plenty of space for storage, improving the efficiency of any organisation. There are a variety of additional options to consider when designing your vehicle - safety modifications to protect the loading area and shelves for flexible organisation of the working space to name a few. A bulkhead with secured sliding door and folding seat (optional extra) improves rear-cabin accessibility making for a more efficient delivery service.

Please get in touch with the Renault Tech team for more information.

**RENAULT
TECH**

Email: debbie.laidlaw@renault.co.uk
Tel: +44 (0) 7966 878 602





Clarks Vehicle Conversions Ltd

As a family business established for over 30 years, and still leading the way in VCA type approval, it is no wonder that Clarks is the country's most trusted producer of Welfare Vehicle conversions.

Crew carriers, racking systems & lifestyle vehicles are also part of their extensive range.

Clarks have invested heavily in making sure their conversions meet the highest safety standards at UK and European levels.

All of their vehicles go through rigorous quality checks before leaving their Conversion Centre.

Clarks support doesn't stop there, they offer nationwide assistance for up to three years on all their conversions as standard.

Also available as an E-Tech electric vehicle.



Tel: 01302 784 490

Email: sales@cvcltd.co.uk





CPL Master Cherry Picker

CPL are the Renault approved access platform converter for the UK. The approved 3.5T Renault Master with a K38PC boom carries a full Renault 3 year warranty and is available across the Renault Master diesel range. This conversion has a payload of up to 320kg and 200kg safe working load in the basket. The working height is 13.7m and the working outreach is 7.4m.



Tel: 01536 529876

Email: mark@cumberlanduk.co.uk

CPL Renault K38P

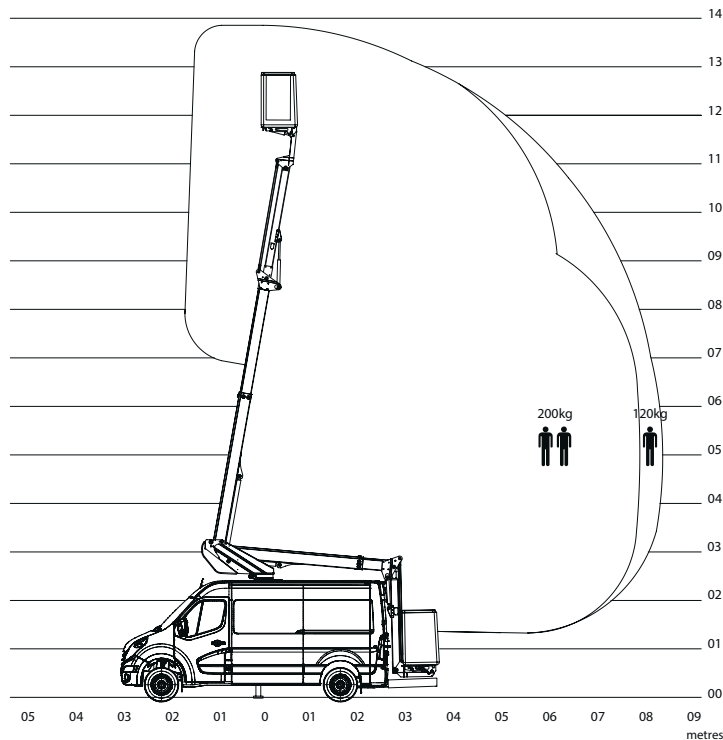

CPL Renault K38P Cutaway

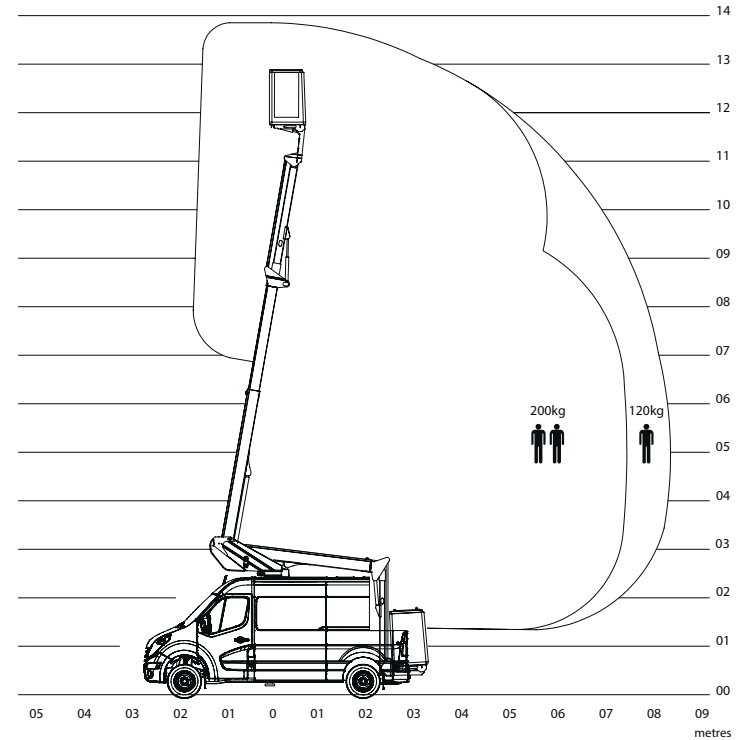



CoolKit Refrigerated Van

CoolKit offers a broad range of refrigerated van conversions.

Their refrigerated vehicle conversions are renowned for their light weight, durability, versatility and strength - attributes which provide our customers with the highest payload and most reliable service throughout the vehicle lifetime.

The conversions have been validated by an unrivalled combination of Standard Certifications and Vehicle Manufacturer Approvals.



Tel: 0845 459 5418

Email: sales@coolkit.co.uk





Truckcraft Bodies Curtainsider

Truckcraft Bodies were established in Manchester in 2003 and founded upon many years of experience in the manufacturing of commercial vehicle bodies, delivering not only a premium product with an emphasis on quality, but also exceptionally high levels of customer service.

The Renault Master Curtainsider offers the combined benefits of payload and volume with easy loading.

The specification is as follows:

- 13'6 (L) x 6'10 (W) x 7'2 (H)
- Aluminium construction
- Wisadeck flooring
- Choice of standard colour curtains
- Optional 500kg column tail lift
- Roller shutter door as standard
(barn doors available as an option)

TRUCKCRAFT
BODIES

Tel: 0161 304 9404

Email: admin@truckcraftbodies.co.uk





BLOOMFIELDS
HORSEBOXES

BLOOMFIELDS

BLOOMFIELDS

BLOOMFIELDS

Bloomfields Master Horse Box

Bloomfields offer a range of 3.5T vehicles based on the Renault Master Platform Cab from their popular Bloomfields ONE to the Eventer Compact with luxury living facility. Bloomfields' market leading strength tested bulkhead set them ahead in the industry. Used throughout Europe by amateurs and professionals alike, Bloomfields are renowned for their strength, safety and build quality.

Always striving to stay ahead with their innovation, Bloomfields have a dedicated research & development department who work tirelessly to create new innovative features and test new materials to be sure that all of their horseboxes are as strong and safe as can be.

Bloomfields are renowned for their bespoke finishes. All horseboxes are built to order and there are rarely 2 alike. Each customer is invited to work with Bloomfields' in-house designers and technicians to ensure that every horsebox meets each individual's needs and requirements.

Bloomfields' in-house spray team mask and spray every design by hand. A one colour metallic is included in the Legacy, Eventer and Professional range but customers have a choice to have their horseboxes personalised with a custom spray design. Matte and flip finishes are one of Bloomfields' signature designs. Each horsebox is baked in one of the spray bake booths to ensure a lasting finish.



Tel: 01623 869779

Email: info@bloomfields.co





Patient Transport Vehicle

Blue Light Services was formed in 2011 after identifying a gap in the market for high quality emergency and non-emergency vehicles. We have grown year on year servicing the NHS, private companies and prison services.

Our senior management team are very proud to have over 25 years of experience in the ambulance industry, both operationally and in supporting private and NHS customers. We believe that each customer is an individual with specific requirements; working with them we will create a design that meets every requirement, as well as that of your service users and regulatory bodies. Our operational background gives us a unique insight into the challenges faced by the modern ambulance, which allows us to understand the importance of every detail on the vehicle.

Key Features

- Seat belt alert system for all seats
- GRP antibacterial wall liners
- Heavy duty manual ramp
- 8 channel CCTV & DVR
- Winch
- Wipe clean blinds
- Side step stowed within vehicle floor
- Upper seat belt anchorages
- Storage pen for wheelchair, carry chair and medical bags



Tel: 020 8965 8357

Email: bluelightservices@mail.com

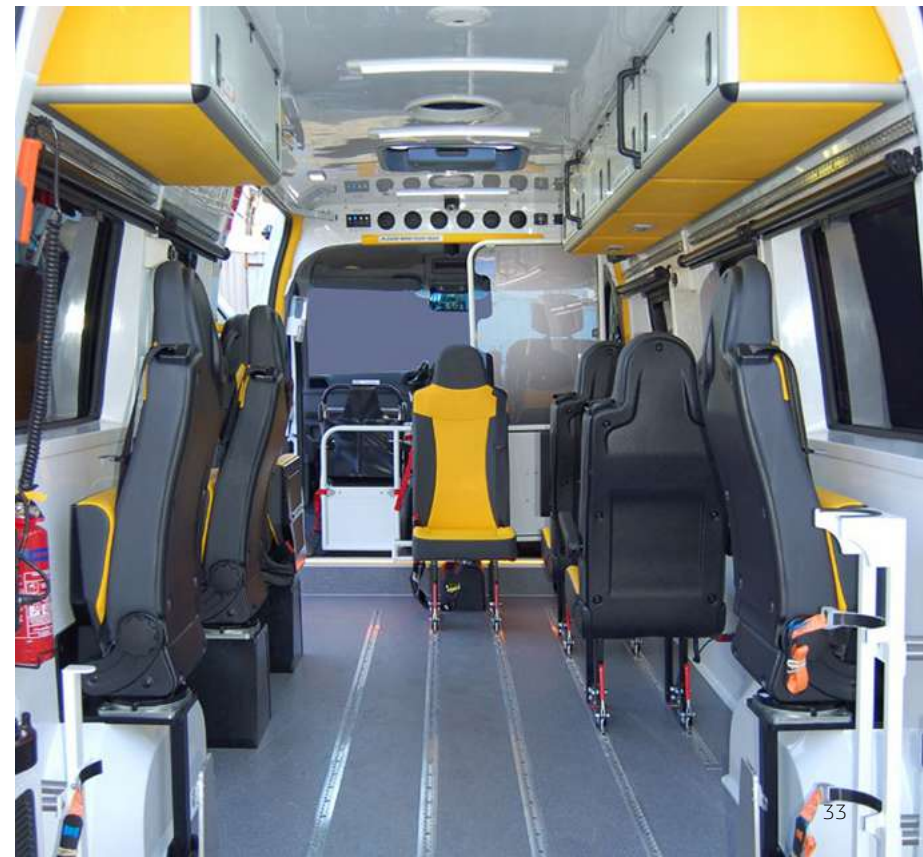



Master AKFS Load & Go[®]

The Renault Master Beavertail conversion, is based on the Renault Master FWD 3.5T chassis cab (ML35) and is completed by AKFS. Idverde UK, a division of Europe's largest provider of grounds maintenance services and landscape construction projects, has chosen the specialised conversion as part of its latest Renault Master order. Power is provided by the efficient 135 bhp dCi 2.3-litre turbo diesel engine, which is complemented by a six-speed manual transmission.

The conversion by AKFS conforms to the European Community Whole Vehicle Type Approval and includes such features as an aluminium bulkhead, aluminium drop sides, spring assisted aluminium tailgate, LED side marker lights on the nearside and offside of the body plus additional options available such as a LED compact light bar and a folding directional sign located on the rear tailgate.

The AKFS Load & Go[®] comes with a standard Renault 100,000-mile/three-year warranty on the base Renault MASTER, while the quality of the conversion is illustrated through AKFS matching the manufacturer's cover.



Tel: 01246 250022

Email: info@advanced-kfs.co.uk





Master AKFS Drop & Go[®] Traffic Management Vehicle

The AKFS Drop & Go[®] Traffic Management vehicle available in 2 variations. Based on a Renault Master Platform Cab and built in line with the requirements of Renault UK to the same specification our long-established Drop & Go[®] models including the rear spring assisted ramp and Hinged LP13 or fixed rear gantry. With the low floor height on the Renault Master Platform Cab it made the sense to add this to our ever-expanding product portfolio at just 595mm bed height to the rear. While removing the need to have a tail lift making it the ideal solution for both inner city environments and major road networks, whilst enabling operatives to step on and off the vehicle quickly and safely. Available payload up to 1139kg including ¼ tank of fuel and driver at 75kg.

Body Specification:

Body style: Closed deck with flat bed

Body width: 2180mm – Body internal / 2240mm – Protection rail external

Body length: 3790mm (Internal min.)

Floor: 1-piece anti slip floor

Aluminium wheel boxes with storage and lockable access door to front face

Recessed lashing rings in floor (x 10)

Integral rear light units and LED side marker lights

Aluminium frame bulkhead; solid panel with aluminium barley seed wear plate and operative's grab handles

Lashing points mounted on bulkhead frame (x 4) plus double 'D' buffer across top edge

Aluminium frame rear gantry with 1000mm central spring assisted tailgate

Drop sides forward of the wheel boxes

Two telescopic protection rails on each side of vehicle (safety yellow)

Standard Equipment included:

700mm LED light bar

Amber LED flashers in grill (x 2)

Audible reversing alarm

Amber LED flashers at rear (x 4)

Reversing camera

Work lights (x 2)

Chapter 8 graphics pack

Also available as an E-Tech electric vehicle.



Tel: 01246 250022

Email: info@advanced-kfs.co.uk



Renault TRAFIC Passenger Wheelchair Accessible Vehicle

Renault have developed a specialist Wheelchair Accessible Vehicle (WAV) version of the TRAFIC Passenger.

The TRAFIC WAV complies with European Whole Vehicle Type Approval, on accessibility conditions for people with reduced mobility or wheelchair users.

The conversion is based on the TRAFIC 9 seat Passenger, with a 3-fold aluminium ramp, which allows easy access to the rear of the vehicle. There is a standard anti-slip floor and 4 detachable tie down clamps for wheelchairs with 4 manually adjustable retractors to restrain the wheelchair in its position.

The Renault TRAFIC WAV is available as an option on all SWB and LWB variants in the following configurations:

- 9/8 seat with wheelchair position (up to 6 of which can be used when utilising the wheelchair position).
- 6/5 seat with wheelchair position.
- 6/5 seat with wheelchair position and folding rear side seat next to the wheelchair position.

RENAULT
TECH

Email: debbie.laidlaw@renault.co.uk

Tel: +44 (0) 7966 878602



Accredited Converter Capabilities

	Emergency Services (Fire, Police, Ambulance)	Patient Transport (PTS)	First Response Vehicles	Minibus	Crew Vans	Highway Maintenance Vehicles	Welfare Vehicles	Reduced Mobility Transport & Wheelchair Access (WAV)	Tipper / Dropside / Box / Luton / Curtainsider	Temperature Control (Fridge / Freezer / Chilled)	Catering Vehicle	Tail lift	Vehicle carrier	Cherry Picker / Cranes & Lifts	Motor Homes & Campers	Internal Firmment (Racking, Stores, Workshop)	Livestock Transport (Inc. Horsebox)	Taxi
Advance KFS Special Vehicles Ltd				•	•	•			•				•					
Babcock Vehicle Engineering Ltd	•	•						•				•						
Bloomfields Horseboxes																	•	
Blue Light Services	•	•	•															
Bri-Stor Systems Ltd							•				•	•		•		•		
Cartwright Conversions		•						•	•			•						
Clarks Vehicle Conversions Ltd				•	•		•									•		
Coleman Milne												•						
CoolKit Ltd										•								
Co-Trim		•		•	•		•	•										•
Courtside Conversions Ltd				•				•										
CPD Bodies Ltd						•			•									
Cumberland Platforms Ltd														•				
Euromotive (Kent) Ltd	•	•		•	•		•	•				•						
GM Coachwork Ltd				•				•										
GRP Leeds Ltd										•								
Icecraft UK										•	•							
Ingimex Ltd									•			•						
J&J Conversions Ltd													•					
Mellor Coachcraft	•	•		•				•										
Minibus Options Ltd		•			•			•										
Modul-System Ltd																•		
Oughtred & Harrison (Facilities) Ltd	•	•		•	•			•										
Penny Hydraulics Ltd														•				
Renault Tech	•				•			•	•			•						
Solomon Commercials Ltd										•								
Sortimo UK Ltd																•		
Stanford Coachworks Ltd	•	•		•	•			•										
Sussex Campervans															•			
TBC Conversions Ltd				•	•			•		•								•
TGS Group									•									
The Cold Consortium Ltd										•								
Treka Bus				•				•										
Trucksmith Ltd									•									
Truckcraft Bodies Ltd									•	•		•						
VFS (Southampton) Ltd									•									
Vic Young (South Shields) Ltd	•	•		•	•		•	•	•	•		•						•
Voyager MPV Ltd					•			•								•		•
Warnerbus Ltd		•		•	•			•										•
Wilker UK Ltd	•	•		•	•			•										



Renault Accredited Converters



AKFS

Web: www.advanced-kfs.co.uk
E-mail: info@advanced-kfs.co.uk
Tel: 01246 250022



trusted to deliver™

Babcock Vehicle Engineering Ltd

Web: www.vehicleengineering.co.uk
E-mail: vehicle.engineering@babcockinternational.com
Tel: 01922 725560



Bloomfields

Web: www.bloomfields.co/
E-mail: info@bloomfields.co
Tel: 01623 869779



Blue Light Services Ltd

Web: www.bluelightservices.com
E-mail: bluelightservices@mail.com
Tel: 020 8965 8357



Bri-Stor Systems

Web: www.bri-stor.co.uk
E-mail: sales@bri-stor.co.uk
Tel: 01889 271 202



Cartwright Conversions

Web: www.cartwrightconversions.co.uk
E-mail: sales@cartwrightconversions.co.uk
Tel: 0330 345 4141



Clarks Vehicle Conversions Ltd

Web: www.van-conversions.com
Tel: 01302 784 490



Coleman Milne

Web: www.coleman-milne.co.uk
E-mail: info@coleman-milne.co.uk
Tel: 01942 815600



Coolkit

Web: www.coolkit.co.uk
E-mail: sales@coolkit.co.uk
Tel: 0845 459 5418



CoTrim

Web: www.cotrim.co.uk
Contact: www.cotrim.co.uk/contact.html
Tel: 01722 324 524

Courtside Conversions Ltd

Courtside Conversions

Web: www.courtsideconversions.co.uk
E-mail: courtsidesales@aol.com
Tel: 01884 256048



CPD

Web: www.cpdbodies.com
E-mail: info@cpdbodies.com
Tel: 01642 607 061



CPL

Web: www.cumberlanduk.co.uk
E-mail: mark@cumberlanduk.co.uk
Tel: 01536 529876



Euromotive

Web: www.euromotive.co.uk
E-mail: sales@euromotive.co.uk
Tel: 01303 267900



GM Coachworks

Web: www.gmcoachwork.co.uk
E-mail: sales@gmcoachwork.co.uk
Tel: 01626 853050



GRP Group

Web: www.grp-group.co.uk
E-mail: sales@grp-group.co.uk
Tel: 0113 255 4664



Icecraft

Web: www.icecraftuk.com
E-mail: enquiries@icecraftuk.com
Tel: 01258 837772



Ingimex

Web: www.ingimex.com
E-mail: sales@ingimex.com
Tel: 01952 585833



J&J Conversions

Web: www.jjconversions.co.uk
E-mail: info@jjconversions.co.uk
Tel: 01264 332919



Mellor Coachcraft

Web: www.mellor-coachcraft.co.uk
E-mail: info@mellor-coachcraft.co.uk
Tel: 01706 860610



Minibus Options

Web: www.minibusoptions.co.uk
Contact: www.minibusoptions.co.uk/contact
Tel: 01663 735355



Modul-System Ltd

Web: www.modul-system.co.uk
E-mail: sales@modul-system.co.uk
Tel: 01628 528034



O and H Vehicle Conversions

Web: www.oh-vehicleconversions.co.uk
E-mail: mboswell@ohvc.co.uk
Tel: 01405 769867



Penny Hydraulics

Web: www.pennyhydraulics.com
E-mail: sales@pennyhydraulics.com
Tel: 01246 811475



Renault Tech

E-mail: debbie.laidlaw@renault.co.uk
Tel: +44 (0) 7966 878602



Solomon Commercial

Web: www.solomoncommercial.co.uk
E-mail: sales@solomoncommercial.co.uk
Tel: 01706 211211



Sortimo UK Ltd

Web: www.mysortimo.co.uk/en_UK
E-mail: cjones@sortimo.co.uk
Tel: 01925 848228



Stanford Coachworks

Web: www.stanfordcoachworks.co.uk
E-mail: sales@stanfordcoachworks.co.uk
Tel: 01375 676088



Sussex Campervans

Web: www.sussexcampervans.com
E-mail: hello@sussexcampervans.com
Tel: 01403 336369



TGS Group

Web: www.tgs-group.com
Email: sales@tgs-group.com
Tel: 0117 965 9965



Taxi & Bus Conversions

Web: www.taxiandbusconversions.co.uk
E-mail: sales@taxiandbusconversions.co.uk
Tel: 028 8772 2666



The Cold Consortium

Web: www.coldconsortium.co.uk
E-mail: sales@coldconsortium.co.uk
Tel: 01430 861373



Treka Bus

Web: www.trekabus.com
E-mail: enquiries@trekabus.com
Tel: 01484 400889



Truckcraft Bodies

Web: www.truckcraftbodies.co.uk
E-mail: admin@truckcraftbodies.co.uk
Tel: 0161 304 9404



Trucksmith

Web: www.trucksmith.com
E-mail: mail@trucksmith.co.uk
Tel: 01884 33001



VFS

Web: www.vfs.co.uk
E-mail: sales@vfs.co.uk
Tel: 023 80 613 612



Vic Young Limited

Web: www.vicyoung.co.uk
E-mail: vic@vicyoung.co.uk
Tel: 0191 427 1566



Voyager Multi Purpose Vehicles

Web: www.voyagermpv.co.uk
E-mail: sales@voyagermpv.co.uk
Tel: 01270 256 670



Warnerbus

Web: www.warnerbus.com
E-mail: enquiries@warnerbus.com
Tel: 01582 965738



Wilker

Web: www.wilkergroup.com
E-mail: info@wilkergroup.com
Tel: 01270 765 999

Renault PRO+, the specialist brand



You're the expert in your field and at Renault PRO+ we're here to guide you through ours. We're passionate about delivering products and services to move your business forward. So when you choose to partner with Renault PRO+ you can expect:

Specialist network

Renault PRO+ Centres have a dedicated commercial vehicle specialist. So whatever you're seeking advice on, there's always someone to help.

Business Commitment

Come rain or shine, we have a set of commitments in place to help maximise uptime and minimise downtime.

The future today - 100% electric

Renault PRO+ has been building, selling and maintaining electric vans since 2011. So when you're looking to make the switch, you know who to speak to.

A tailored approach

Your vehicles are as unique as your business. That's why we have a programme of conversions to deliver exactly the product you want. From 'off the shelf' conversions to a more bespoke approach. We'll guide you through.

Renault services

3 Years Warranty

Your vehicle is covered by a warranty package for up to 3 years from date of first registration (unlimited mileage during the first 24 months, followed by a further 1 year limited to a total mileage of 100,000). Your Renault Dealer is able to repair or replace without charge, parts that are found to have a material or assembly defect that is recognised by Renault. The paintwork warranty runs for 3 years and the anti-corrosion warranty for 6 years.

For Warranty Terms and Conditions please visit www.renault.co.uk/warranty.

3 Years Renault Assistance

Should you need it, we'll provide emergency roadside repairs or tow you to the nearest Renault Dealer. This service is available 24 hours a day and is provided for 36 months from the date of first registration (unlimited mileage for first 24 months, then limited to a total of 100,000 miles or 3 years, whichever comes first). Assistance is provided within the UK & Northern Ireland only at roadside, home and includes national recovery and onward travel. Assistance applies to mechanical or electrical defects which are covered by warranty.

For Renault Assistance Terms and Conditions please visit www.renault.co.uk/assistance.

Service Intervals

MASTER & TRAFIC Diesel: 24,000 miles / 2 years

MASTER E-Tech electric Year 1 / 12,000 miles, Year 2 / 24,000 miles and then every 2 years / 24,000 miles

Renault Network Services

No-one is better placed than Renault to maintain, fit and repair your Renault, fast. The Renault Minute (maintenance and repair with no appointment necessary) and Renault Rapide Bodycare (bumper scuffs, dings and dents, windscreen, stone chips and interior repairs...) services deliver the highest level of repair and maintenance and offer a full year's guarantee on original Renault parts. Don't forget to have a look at our wide range of additional equipment and accessories!

Renault iCare

Is an innovative Service, Maintenance & Repair product that supplies Business customers with a fully supported, managed hassle free service and maintenance package.

Renault iCare is a "Pay-As-You-Go" product that insures your vehicle is maintained by Renault technical experts when work is required.

iCare provides the following benefits:

- Full Service, Maintenance & Repair cover in the Renault Dealer Network
 - Tyres can be included within the contract at an additional fixed cost
 - Ancillary equipment can also be included (at an additional fixed monthly cost)
 - Excludes: Damage/Neglect/Abuse/Glass & Bulbs
- A fixed, pre agreed pence per mile rate
- No excess mileage charges at the end of the contract
- No pooled mileage administration
- Minimalise downtime

For more information and to obtain a quote based on your requirements, please speak to your local Renault Business dealer or visit www.renault.co.uk/icare

Customer Relations

Renault knows the value of communicating with its customers and we have established effective ways to keep in touch with you. If, after speaking to your local Renault dealership, you are not completely satisfied, please contact the Renault UK Customer Relations Team on 0344 3350000* (Mon-Fri 8.00am to 6.00pm, Closed on Bank Holidays. Live Chat Mon-Fri 8.00am to 9.00pm). You can also visit our website www.renault.co.uk or write to us at: Renault UK Ltd, The Rivers Office Park, Denham Way, Maple Cross, Rickmansworth, Hertfordshire, WD3 9YS.

Finance options*

There are numerous ways that you can finance your new vehicle with Renault. Whether you are a fleet or a private buyer, Renault Finance allows you to tailor your payment plan to your needs and circumstances.



*Finance provided by Renault Finance, P.O. Box 149, Watford, WD17 1FJ. Guarantees and indemnities may be required. You must be at least 18 and a UK resident (excludes Isle of Man and Channel Islands) to apply. Subject to status, terms and conditions apply. †Calls to 0330 numbers are free if used as part of your inclusive mobile minutes and are charged at local rates from landlines. Renault UK Limited (company number 82932), registered at The Rivers Office Park, Denham Way, Maple Cross, Rickmansworth, Hertfordshire, WD3 9YS.

Continue the Renault CONVERSIONS experience
at www.renault.co.uk

Although every effort has been made to ensure that the information contained within this brochure is as accurate and up to date as possible, Renault U.K. reserves the right to modify its models without notice, including their characteristics, specifications, equipment and accessories. Brochures inevitably become out of date or inaccurate in some respects, in that such characteristics, specifications equipment, or accessories may be changed after the publication date given below and can differ from the descriptions given or the photos displayed. It is therefore necessary to check with your Renault Dealer before purchasing any product that the characteristics, specifications, equipment or accessories of the vehicle on order are as advertised. The colours that appear in this document may differ slightly from the actual paint and upholstery colours.

Renault recommends 

 Prodigious

Photo credits: © Renault Marketing 3D-Commerce, A. Bernier, R. Richter, S. Agnetti, O. Banet, D. Meunier – Online only – April 2022