



# ALL-NEW MAZDA CX-5

PRICES & SPECIFICATIONS



## INTRODUCING THE ALL-NEW MAZDA CX-5

The all-new Mazda CX-5 isn't just an SUV—it's a statement. With its sleek design and purposeful stance, it reflects a lifestyle built on confidence, sophistication, and the freedom to explore more.

Every element has been thoughtfully designed to elevate your driving experience. From its refined interior to its intuitive features, the Mazda CX-5 offers comfort, versatility, and a sense of calm—whether you're navigating the city or escaping it.

Crafted around you, it blends Mazda's human-centric philosophy with advanced technology to deliver a drive that feels natural, responsive, and reassuring. It's more than just getting from A to B—it's about enjoying the journey.

And with Mazda's signature Jinba-Ittai driving dynamics, the Mazda CX-5 creates a seamless connection between car and driver. It's agile, composed, and effortlessly in tune with your every move—turning everyday drives into moments of pure enjoyment.

**6** YEAR MAZDA  
WARRANTY

CRAFTED WITH JAPANESE SOUL

## THE LATEST IN TECHNOLOGY & CONVENIENCE

### DESIGN THAT MOVES YOU

The all-new Mazda CX-5 showcases the next evolution of our award-winning Kodo design philosophy, delivering a bold, sporty presence that is unmistakably CX-5. Its perfectly balanced proportions create a strong stance, emphasising all four wheels for a sense of stability and control.

At the front, the commanding design is complemented by distinctive Signature Daytime Running Lights\* and Mazda's iconic five-point grille, creating a look that exudes confidence. At the rear, a wide tread and dual exhaust system provide a refined finish that ensures the Mazda CX-5 stands out from every angle—so striking, you'll want to glance back every time you park.

(\*Standard on Homura grades)



### CRAFTED FOR THOSE WHO APPRECIATE DETAIL

It's the little design details that make the Mazda CX-5 truly captivating. At first glance, its body surfaces appear simple, yet they are precisely sculpted to play with light and shadow, reflecting the surroundings in a way that is uniquely Mazda. Look closer and you'll notice the subtle red accents inside the headlamps, emphasising the car's wide stance and featuring a discreet '5'—a nod to its CX-5 identity.

From these thoughtful touches to the harmonious flow of every contour, the Mazda CX-5 is designed to keep you discovering something new.

## THE LATEST IN TECHNOLOGY & CONVENIENCE

### EFFORTLESS CONNECTIVITY, THOUGHTFULLY DESIGNED FOR SAFETY

At Mazda, we believe technology should enhance your drive—not distract from it, which is why the all-new Mazda CX-5's infotainment system is designed to keep you comfortably connected while staying focused on the road ahead.

The large central touchscreen offers a crisp, customisable display that's easy to read and simple to use. With intuitive touch controls and high-precision voice recognition, accessing key functions like climate control, navigation, and audio is seamless—no fumbling, no frustration.



### CONTROL AT YOUR FINGERTIPS

Complementing our latest infotainment system is our redesigned steering wheel, featuring ergonomically placed switches for quick access to everyday essentials such as drive modes, safety systems, and entertainment. Everything is right where you need it, so you can stay in control and enjoy a safer, more relaxed driving experience.

With the Mazda CX-5, smart technology meets thoughtful design—giving you confidence, clarity, and peace of mind every time you drive.

## THE LATEST IN TECHNOLOGY & CONVENIENCE

### GOOGLE BUILT-IN~

The all-new Mazda CX-5 now features Google built-in, transforming your cabin into a hub of smart functionality for a more comfortable, high-quality driving experience. Access Google Maps for precise, real-time navigation, explore a wide range of apps via the Google Play Store—including favourites like YouTube<sup>^</sup>, Waze and Amazon Music—and look forward to Google Gemini<sup>\*</sup>, an advanced AI assistant that responds without the need for memorising commands.

No more juggling devices or worrying about compatibility. With automatic updates, you'll always have the latest features and security. Whether it's planning the quickest route, streaming your favourite music, or managing your day, Google built-in keeps you connected, informed and in control—making every drive smarter and more enjoyable.



### APPLE CARPLAY® & ANDROID AUTO™

Apple CarPlay® and Android Auto™ seamlessly integrate your smartphone with the Mazda CX-5's infotainment system, keeping you connected while ensuring your hands stay on the wheel and your eyes on the road.

Enjoy real-time navigation, live traffic updates, and effortless access to your favourite music, podcasts, and apps—all through an intuitive interface designed for driving. With voice control and familiar functionality, your smartphone transforms your Mazda CX-5 into a smart, connected hub, making every journey safer, more efficient, and more entertaining.

## THE LATEST IN TECHNOLOGY & CONVENIENCE

### BOSE PREMIUM SOUND: ELEVATING EVERY DRIVE

The all-new Mazda CX-5 is the first Mazda to feature a Bose premium audio system equipped with cutting-edge Perpetual Sound Rendering (PSR) technology. With twelve high-performance speakers strategically positioned throughout the cabin, this advanced system delivers sound that is rich, lifelike and immersive—redefining in-car acoustics for an experience that feels truly exceptional.

This isn't just audio; it's artistry. The system incorporates Bose's latest innovations, including CenterPoint 2, SurroundStage, BassSync, BassMatch, and AUDIOPILOT, working together to create a dynamic soundscape that adapts to your environment. The result? Music that feels as vibrant and powerful as a live performance—transforming every journey into something extraordinary.

(Standard on Exclusive-Line and Homura grades)

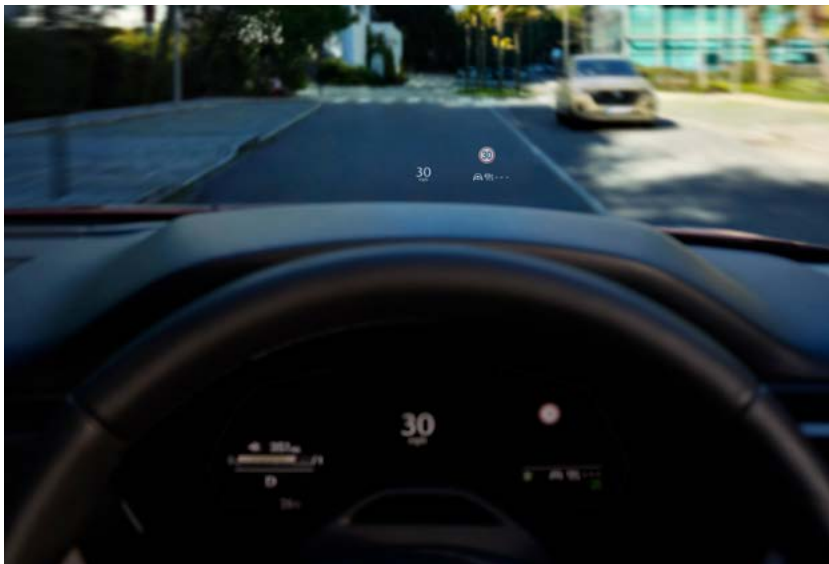

### COLOUR ACTIVE DRIVING DISPLAY

The windscreen-projected colour Active Driving Display puts key information within your line of sight, so you can keep your focus on the road ahead.

Essential details such as vehicle speed, cruise control settings and satellite navigation directions are displayed clearly on the windscreen, reducing distractions and helping you drive with confidence.

(Not available on Prime-Line grade)

## THE LATEST IN TECHNOLOGY & CONVENIENCE

### MAZDA CO-PILOT CONCEPT: ADVANCED DRIVING SUPPORT

At Mazda, we believe driving is more than a means of getting from A to B. That's why our advanced driving support technology is designed with one clear principle: the driver always comes first.

Mazda Co-Pilot Concept is designed to keep a constant watch on the driver's condition—whether navigating city streets or cruising on motorways—to help reduce accidents and minimise damage. Beyond protecting the driver and passengers, this innovative system offers peace of mind to families, friends, and everyone sharing the road, reinforcing Mazda's commitment to safety for all.



### i-ACTIVSENSE SAFETY TECHNOLOGIES: HELPING YOU RECOGNISE AND AVOID POTENTIAL HAZARDS

i-ACTIVSENSE is Mazda's suite of advanced safety and driver-assistance technologies, designed to help prevent accidents and reduce their severity.

Using a network of cameras and sensors, these systems detect potential hazards and provide timely support to the driver. Key features include **Mazda Radar Cruise Control**, which maintains a safe speed and following distance, while technologies such as **Blind Spot Monitoring**, **Emergency Lane Keeping**, and **Smart Brake Support** work together to help avoid collisions or minimise their impact—making every journey safer and more confident.

## THE FLEXIBILITY TO FIT INTO YOUR LIFE

### WEEKEND AWAY, PACK YOUR BAGS

Your ultimate companion for the perfect weekend getaway. With a spacious 583-litre boot, the Mazda CX-5 ensures you can bring everything you need.

Practicality is taken to new heights with the 40:20:40 split rear seats, offering versatile loading options and expanding capacity to an impressive 2,019 litres.

Need to load the boot with your hands full? No problem—simply swipe your foot beneath the rear bumper, and the hands-free power liftgate\* will effortlessly open or close.

(\*Standard on Homura grade)



## PRIME-LINE



Mazda CX-5 141ps 2WD Prime-Line Auto in Arctic White

## Recommended on the road\* from £31,550



17" Grey alloy wheels



Premium Black cloth seat trim



12.9" Colour touch screen centre display

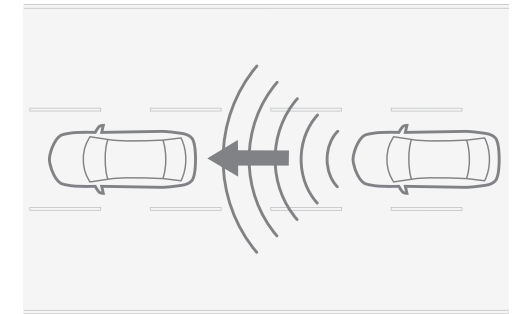

Mazda Radar Cruise Control

## STANDARD FEATURES

### EXTERIOR

- 17" Grey alloy wheels
- Gloss Black electrically adjustable door mirrors
- Front & rear parking sensors
- Reversing camera
- Dusk-sensing lights
- Rain-sensing front wipers
- LED headlights with LED daytime running lights
- Coming home / leaving home lights
- High Beam Control (HBC)
- Headlight washers
- Satin Black lower front & rear bumper and wheel arch mouldings

### INTERIOR

- Premium Black cloth seat trim
- Colour 10.25" LCD instrument cluster display (provides speed, traffic signs and cruise control information)
- Electronic Parking Brake with Auto hold
- Leather-wrapped steering wheel & gear shift
- Seats (front)
  - Driver seat manual tilt, slide, recline and height adjustment
  - Passenger seat manual slide, recline and height adjustment
- Seats (rear)
  - 40:20:40 split fold down rear seats
  - Manual recline
  - Folding centre armrest equipped w/2 cup holders

### SAFETY & SECURITY

- Blind Spot Monitoring with Rear Cross Traffic Alert
- Driver Attention Alert
- Driver Emergency Assist
- Driver Monitoring
- e-Call with GPS
- Emergency Lane-Keeping
- Front Cross Traffic Alert
- Intelligent Speed Assistance
- Lane Departure Warning System
- Proactive Driving Support
- Remote central locking
- Smart Brake Support
- Traffic Sign Recognition with intelligent speed assist
- Vehicle exit warning

### COMFORT & CONVENIENCE

- Mazda Radar Cruise Control (MRCC) (Features Stop & Go function)
- Cruising & Traffic Support (CTS)
- Front & rear electric windows
- Dual zone climate-controlled air-conditioning
- Mi-DRIVE: drive mode selection

### INFOTAINMENT

- AM / FM / DAB radio, with 8 speakers and two USB-C inputs
- Connected Services<sup>^</sup>
- Integrated Bluetooth<sup>®</sup>
- 12.9" Colour touch screen centre display
- Google built-in (including Google Gemini, Google Maps and Google Play)
- Wired Apple CarPlay<sup>®</sup> & Android Auto<sup>™</sup>

<sup>^</sup>Connected Services is a subscription service and requires a compatible mobile device to download and sign-up to the MyMazda App. A 7-year complimentary period is included and commences from the date of first registration of the vehicle.

\*Recommended OTR price includes VAT, number plates, delivery to the dealer, 12 months' Vehicle Excise Duty (VED), first registration fee, 6-year or 100,000 mile warranty and 3 years' European roadside assistance.

## CENTRE-LINE



Mazda CX-5 141ps 2WD Centre-Line Auto in Soul Red Crystal

Recommended on the road\* from £34,050



19" Black Machined alloy wheels



Black Artificial Leather and Suede-like material seat trim



Windscreen projected colour Active Driving Display



Gloss Black roof rails

### STANDARD FEATURES – in addition to Prime-Line, Centre-Line adds:

#### EXTERIOR

- 19" Black Machined alloy wheels
- Door Mirrors
  - Heated, auto power folding door mirrors
  - Selectable tilt-down function (reverse)
  - with memory
- Power liftgate
- Rear privacy glass
- Gloss Black roof rails
- Front wiper de-icer

#### INTERIOR

- Black Artificial Leather and Suede-like material seat trim
- Frameless auto-dimming rear-view mirror
- Heated, leather-wrapped steering wheel
- Seats (front)
  - Driver seat electric tilt, slide, recline, height & lumbar adjustment
  - Driver seat memory
  - Heated with 3-stage setting

#### COMFORT & CONVENIENCE

- Dual zone climate-controlled air-conditioning with rear air vents
- Windscreen Projected colour Active Driving Display (Head-up Display)

#### INFOTAINMENT

- Qi wireless charging
- Wireless Apple CarPlay® & Android Auto™

\*Recommended OTR price includes VAT, number plates, delivery to the dealer, 12 months' Vehicle Excise Duty (VED), first registration fee, 6-year or 100,000 mile warranty and 3 years' European roadside assistance.

## EXCLUSIVE-LINE



Mazda CX-5 141ps AWD Exclusive-Line Auto in Machine Grey

Recommended on the road\* from £36,550



360° View Monitor<sup>^</sup>



Electric Panoramic Sunroof<sup>^</sup>



12 Bose speaker surround-sound system



Two rear USB-C Inputs<sup>^</sup>

### STANDARD FEATURES – in addition to Centre-Line, Exclusive-Line adds:

#### EXTERIOR

- 360° View Monitor with see-through view
- Electric panoramic sunroof

#### INTERIOR

- Seats (front)
  - Passenger seat electric slide, recline, & height adjustment
- Seats (rear)
  - Heated with 3-stage setting

#### COMFORT & CONVENIENCE

- Mi-DRIVE: Off-road mode (AWD models only)

#### SAFETY & SECURITY

- Hill Descent Control (AWD models only)

#### INFOTAINMENT

- AM / FM / DAB radio featuring 12-Speaker Bose surround sound system, with Perceptual Sound Rendering, BassMatch and AudioPilot 3 technology.
- USB-C inputs (x2 rear)

#### OPTIONAL INTERIOR COLOURATION

- Two-tone Pure White & Black Artificial Leather and Suede-like material seat trim - including Pure White centre console trim and Door Panel & Dashboard inserts

<sup>^</sup>Specification varies by model grade. Image shown depicts Homura grade.

\*Recommended OTR price includes VAT, number plates, delivery to the dealer, 12 months' Vehicle Excise Duty (VED), first registration fee, 6-year or 100,000 mile warranty and 3 years' European roadside assistance.

# HOMURA



Mazda CX-5 141ps AWD Homura Auto in Aero Grey

Recommended on the road\* from £38,950



19" Black alloy wheels



Black Leather<sup>^</sup> seat trim



15.6" Colour touch screen display



Power liftgate with handsfree function

## STANDARD FEATURES – in addition to Exclusive-Line, Homura adds:

### EXTERIOR

- 19" Black alloy wheels
- Door Mirrors
  - Auto-dimming drivers door mirror
- Adaptive LED Headlights
- Front & rear Signature LED daytime running lights
- Power liftgate with handsfree function
- Gloss Black lower front & rear bumper and wheel arch mouldings

### INTERIOR

- Black Leather<sup>^</sup> seat trim
- Seats (front)
  - Mazda Driver Personalisation System
  - Ventilation with 3-stage setting
- Steering wheel mounted paddle shift

### COMFORT & CONVENIENCE

- Interior ambient lighting

### INFOTAINMENT

- 15.6" Colour touch screen centre display

### OPTIONAL INTERIOR COLOURATION

- Sport Tan Leather<sup>^</sup> seat trim - including Sport Tan centre console trim and Door Panel & Dashboard inserts

<sup>^</sup>Leather refers to centre seat facing and side supports.

\*Recommended OTR price includes VAT, number plates, delivery to the dealer, 12 months' Vehicle Excise Duty (VED), first registration fee, 6-year or 100,000 mile warranty and 3 years' European roadside assistance.

# PRICING

|  | PRICE      | VAT       | P11D VALUE <sup>1</sup> | FIRST YEAR VED & DVLA FIRST REG FEE <sup>2</sup> | RECOMMENDED ON THE ROAD <sup>3</sup> | CO <sub>2</sub> EMISSIONS COMBINED (g/km) <sup>4</sup> | BIK TAX (%) <sup>5</sup> | 2026/27 MONTHLY TAX LIABILITY 20%/40% | INSURANCE GROUP |
|--|------------|-----------|-------------------------|--|--------------------------------------|--|--------------------------|---------------------------------------|-----------------|
| <b>2WD e-SKYACTIV G MHEV</b>                 |            |           |                         |  |                                      |  |                          |                                       |                 |
| Mazda CX-5 2.5 141ps 2WD Prime-Line Auto     | £25,070.83 | £5,014.17 | £30,085                 | £1,465   | £31,550                              | 157  | 37%                      | £186/£371                             | TBC             |
| Mazda CX-5 2.5 141ps 2WD Centre-Line Auto    | £27,154.17 | £5,430.83 | £32,585                 | £1,465   | £34,050                              | 158  | 37%                      | £201/£402                             | TBC             |
| Mazda CX-5 2.5 141ps 2WD Exclusive-Line Auto | £29,237.50 | £5,847.50 | £35,085                 | £1,465   | £36,550                              | 159  | 37%                      | £216/£433                             | TBC             |
| Mazda CX-5 2.5 141ps 2WD Homura Auto         | £31,237.50 | £6,247.50 | £37,485                 | £1,465   | £38,950                              | 159  | 37%                      | £231/£462                             | TBC             |
| <b>AWD e-SKYACTIV G MHEV</b>                 |            |           |                         |  |                                      |  |                          |                                       |                 |
| Mazda CX-5 2.5 141ps AWD Exclusive-Line Auto | £30,904.17 | £6,180.83 | £37,085                 | £1,465   | £38,550                              | 169  | 37%                      | £229/£457                             | TBC             |
| Mazda CX-5 2.5 141ps AWD Homura Auto         | £32,904.17 | £6,580.83 | £39,485                 | £1,465   | £40,950                              | 169  | 37%                      | £243/£487                             | TBC             |

1 - Petrol/diesel/alternative fuel cars with a list price of over £40,000 (including VAT, paint, and factory fitted options) at first registration, the customer will have to pay an additional VED charge (currently £440) for five years from the start of the second licence (in addition to the standard VED charge per year, currently £200 for all vehicles).

2 - First year rate Vehicle Excise Duty as of 1 April 2026, includes £55 DVLA first registration fee.

3 - Recommended OTR price includes VAT, number plates, delivery to the dealer, 12 months' Vehicle Excise Duty (VED), first registration fee, 6-year or 100,000 mile warranty and 3 years' European roadside assistance.

4 - Figures shown are for comparability purposes. Only compare CO<sub>2</sub> figures with other cars tested to the same technical procedures. These figures may not reflect real life driving results, which will depend upon a number of factors including the accessories fitted (post registration), variations in weather, driving styles and vehicle load. All figures quoted are derived from the latest WLTP test cycle.

5 - BIK tax figures quoted per month in 2026/27 (except Scotland).

Pricing and specifications are subject to change. Please speak with your local dealer for latest pricing information.

## PAINT FINISH OPTIONS



ARCTIC WHITE | £0



AERO GREY | £700



POLYMETAL GREY | £700



JET BLACK | £700



NAVY BLUE | £700



RHODIUM WHITE | £800



MACHINE GREY | £800



SOUL RED CRYSTAL | £1,000

Use our car configurator to find the perfect Mazda CX-5 for you.



BUILD YOUR MAZDA CX-5

# MAZDA CX-5 INTERIOR TRIMS AND COLOURATION



Premium Black cloth seat trim - including Black centre console trim and door panel & dashboard inserts  
**PRIME-LINE**



Black Artificial Leather and Suede-like material seat trim - including Black centre console trim and door panel & dashboard inserts  
**CENTRE-LINE & EXCLUSIVE-LINE**



Two-tone Pure White & Black Artificial Leather and Suede-like material seat trim - including Pure White centre console trim and door panel & dashboard inserts  
**OPTIONAL ON EXCLUSIVE-LINE**



# MAZDA CX-5 INTERIOR TRIMS AND COLOURATION



Black Leather<sup>^</sup> seat trim - including Black centre console trim  
and door panel & dashboard inserts  
**HOMURA**



Sport Tan Leather<sup>^</sup> seat trim - including Sport Tan centre console  
trim and door panel & dashboard inserts  
**OPTIONAL ON HOMURA**



<sup>^</sup>Leather refers to centre seat facing and side supports.

Mazda Motors UK reserves the right to introduce changes in pricing, specification and equipment due to its ongoing product development. Colour and trim samples shown in this digital brochure may vary from the actual colours because of the variations of resolutions and colours found in various screen displays, and if printed, limitations within the printing process. Models shown may not be to UK specification. It is recommended that you consult your Mazda dealer when referring to these.

## MAZDA CX-5 ALLOY WHEELS



17" Grey alloy wheels  
(PRIME-LINE)



19" Black Machined alloy wheels  
(CENTRE-LINE & EXCLUSIVE-LINE)



19" Black alloy wheels  
(HOMURA)

# EQUIPMENT

|  |  | PRIME-LINE | CENTRE-LINE | EXCLUSIVE-LINE | HOMURA |
|--|--|------------|-------------|----------------|--------|
| <b>EXTERIOR</b>  |  |            |             |                |        |
| B-Pillar and C-Pillar garnish  | Gloss Black  | ●          | ●           | ●              | ●      |
| Door mirrors:  | Gloss Black  | ●          | ●           | ●              | ●      |
|  | Electrically-adjustable door mirrors   | ●          | ●           | ●              | ●      |
|  | Heated, auto power-folding door mirrors  | -          | ●           | ●              | ●      |
|  | Selectable tilt-down function when in reverse with auto-dimming (Drivers mirror only)  | -          | ●           | ●              | ●      |
|  | with memory  | -          | ●           | ●              | ●      |
| Front Grille:  | Satin Black  | ●          | ●           | ●              | ●      |
| Front Signature Wing   | Grey   | ●          | ●           | ●              | ●      |
| Headlights:  | Adaptive LED Headlights (ALH) - Features 5 modes:<br>- Glare-free High Beam<br>- Highway mode<br>- Marking light<br>- Wide-range Low Beam<br>- Adaptive Front lighting System (AFS)                | -          | -           | -              | ●      |
|  | Coming home / leaving home lights  | ●          | ●           | ●              | ●      |
|  | Dusk-sensing headlights  | ●          | ●           | ●              | ●      |
|  | Headlight washers  | ●          | ●           | ●              | ●      |
|  | High Beam Control (HBC) - detects oncoming and preceding vehicles and automatically switches between high and low beams during night driving, making it easier for the driver to recognise hazards | ●          | ●           | ●              | -      |
|  | LED, with auto headlight levelling   | ●          | ●           | ●              | ●      |
|  | LED daytime running lights   | ●          | ●           | ●              | -      |
|  | Signature LED daytime running lights   | -          | -           | -              | ●      |
| Kodo Turn Signal - distinctive light signature that starts at full power and then fades in sequential pulses |  | ●          | ●           | ●              | ●      |
| Lower front & rear bumper and wheel arch mouldings:  | Satin Black  | ●          | ●           | ●              | -      |
|  | Gloss Black  | -          | -           | -              | ●      |
| Parking sensors:   | Front and Rear   | ●          | ●           | ●              | ●      |
| Parking aids:  | Reversing camera with dynamic guide lines  | ●          | ●           | -              | -      |
|  | 360° View Monitor with See-Through View - offering a complete view of your surroundings through integrated cameras to make low-speed manoeuvres and parking effortless.                            | -          | -           | ●              | ●      |
| Power liftgate   | Operational by button located on dashboard, key fob or button located on tailgate  | -          | ●           | ●              | -      |
| Power liftgate with hands free function  | Operational by button located on dashboard, key fob or button located on tailgate, or by passing your foot underneath the rear bumper with the key in your pocket or bag                           | -          | -           | -              | ●      |
| Privacy glass:   | Rear side and rear windows   | -          | ●           | ●              | ●      |
| Rear lights:   | Signature LED rear combination lights  | -          | -           | -              | ●      |
| Roof rails:  | Gloss Black  | -          | ●           | ●              | ●      |
| Sunroof:   | Electric panoramic   | -          | -           | ●              | ●      |
| Wheels & tyres:  | 17" Grey alloy wheels with 225/65 R17 tyres  | ●          | -           | -              | -      |
|  | 19" Black Machined alloy wheels with 225/55 R19 tyres  | -          | ●           | ●              | -      |
|  | 19" Black alloy wheels with 225/55 R19 tyres   | -          | -           | -              | ●      |
| Wipers:  | Front, rain-sensing with adjustable sensitivity and speed  | ●          | ●           | ●              | ●      |
|  | Front Wiper De-icer - Hot wires located along the drivers side A-pillar and the wiper finishing positions  | -          | ●           | ●              | ●      |
|  | Low washer fluid warning lamp  | ●          | ●           | ●              | ●      |

● = Standard equipment, - = Not available.

Specification and naming conventions are subject to change.

# EQUIPMENT

|   |   | PRIME-LINE | CENTRE-LINE | EXCLUSIVE-LINE | HOMURA |
|---|---|------------|-------------|----------------|--------|
| <b>INTERIOR</b>   |   |            |             |                |        |
| Electronic Parking Brake with auto-hold and auto-disengage function |   | ●          | ●           | ●              | ●      |
| Electrical power outlets:   | 12V outlet (x1 front, x1 luggage compartment)   | ●          | ●           | ●              | ●      |
| Gear shift:   | Leather-wrapped   | ●          | ●           | ●              | ●      |
| Grab handles:   | Driver, front passenger and two rear, with coat hooks   | ●          | ●           | ●              | ●      |
| Coat Hooks:   | Rear x 2  | ●          | ●           | ●              | ●      |
| Instrument cluster:   | Trip computer   | ●          | ●           | ●              | ●      |
|   | Colour 10.25-inch LCD display (provides speed, traffic signs and cruise control information)  | ●          | ●           | ●              | ●      |
| Interior mirror:  | Frameless auto-dimming rear-view mirror   | -          | ●           | ●              | ●      |
| Interior trim:  | Premium Black cloth seat trim - including Black centre console trim and Door Panel & Dashboard inserts  | ●          | -           | -              | -      |
|   | Black Artificial Leather and Suede-like material seat trim - including Black centre console trim and Door Panel & Dashboard inserts   | -          | ●           | ●              | -      |
|   | Two-tone Pure White & Black Artificial Leather and Suede-like material seat trim - including Pure White centre console trim and Door Panel & Dashboard inserts  | -          | -           | ○              | -      |
|   | Black Leather <sup>^</sup> seat trim - including Black centre console trim and Door Panel & Dashboard inserts   | -          | -           | -              | ●      |
|   | Sport Tan Leather <sup>^</sup> seat trim - including Sport Tan centre console trim and Door Panel & Dashboard inserts   | -          | -           | -              | ○      |
| Seats (Front):  | Driver seat manual tilt, slide, recline and height adjustment   | ●          | -           | -              | -      |
|   | Driver seat electric tilt, slide, recline, height and lumbar adjustment   | -          | ●           | ●              | ●      |
|   | Driver seat memory linked to driver door mirror and Active Driving Display (HUD)  | -          | ●           | ●              | -      |
|   | Mazda Driver Personalisation System – Offers personalised comfort with memory settings for the driver's seat, head-up display (HUD), and wing mirrors, along with driver seat ingress/egress support. | -          | -           | -              | ●      |
|   | Passenger seat manual slide, recline and height adjustment  | ●          | ●           | -              | -      |
|   | Passenger seat electric slide, recline and height adjustment  | -          | -           | ●              | ●      |
|   | Heated with 3-stage setting   | -          | ●           | ●              | ●      |
| Ventilation with 3-stage setting                                    | -   | -          | -           | ●              |        |
| Seats (Rear):   | 40:20:40 split fold down rear seats   | ●          | ●           | ●              | ●      |
|   | Manual recline adjustment   | ●          | ●           | ●              | ●      |
|   | Folding centre armrest equipped with two cup holders  | ●          | ●           | ●              | ●      |
|   | Heated outer rear seats with 3-stage setting  | -          | -           | ●              | ●      |
|   | Three height-adjustable head restraints   | ●          | ●           | ●              | ●      |
| Steering wheel:   | Leather-wrapped   | ●          | ●           | ●              | ●      |
|   | Manual telescopic and tilt adjustment   | ●          | ●           | ●              | ●      |
|   | Heated  | -          | ●           | ●              | ●      |
|   | Paddle shift  | -          | -           | -              | ●      |
| Storage spaces:   | Door pockets (driver, front passenger and two rear)   | ●          | ●           | ●              | ●      |
|   | Front centre storage with two cupholders  | ●          | ●           | ●              | ●      |
|   | Glovebox with interior illumination   | -          | -           | ●              | ●      |
|   | Roof mounted sunglasses holder  | ●          | ●           | ●              | ●      |
|   | Seatback pocket (located on rear of front driver and passenger seats)   | -          | ●           | ●              | ●      |

● = Standard equipment, - = Not available, ○ = Optional.

Specification and naming conventions are subject to change. <sup>^</sup>Leather refers to centre seat facing and side supports.

# EQUIPMENT

|  |  | PRIME-LINE          | CENTRE-LINE | EXCLUSIVE-LINE | HOMURA |
|--|--|---------------------|-------------|----------------|--------|
| <b>INFOTAINMENT</b><br>Audio System:     | 12.9-inch colour centre touch-screen display   | ●                   | ●           | ●              | -      |
|  | 15.6-inch colour centre touch-screen display   | -                   | -           | -              | ●      |
|  | AM / FM / DAB radio, with 8 speakers   | ●                   | ●           | -              | -      |
|  | AM / FM / DAB radio featuring 12-Speaker Bose surround sound system, with Perceptual Sound Rendering, BassMatch and AudioPilot 3 technology.   | -                   | -           | ●              | ●      |
|  | Steering wheel-mounted audio and Bluetooth® controls   | ●                   | ●           | ●              | ●      |
|  | USB-C inputs (x2 front)  | ●                   | ●           | ●              | ●      |
|  | USB-C inputs (x2 rear)   | -                   | -           | ●              | ●      |
| Google built-in <sup>1)</sup> :          | Experience Mazda's next-generation Android-powered infotainment system with Google built-in. Enjoy 3-years of familiar Google apps and services optimised for your vehicle, including Google Gemini (AI assistant), Google Maps (for effortless navigation), and a wide range of apps available on Google Play allowing you access to music, videos, games and more. | ●                   | ●           | ●              | ●      |
| Integrated Bluetooth®:                   | Allows audio transfer from Bluetooth® devices, hands-free calling and easy access to phone contacts  | ●                   | ●           | ●              | ●      |
| Mazda Connected Services <sup>2)</sup> : | Connected Services - Accessed via the MyMazda App which provides you with information about your vehicle, you can also access many other features like remote controls, vehicle finder and send a destination to your car  | ●                   | ●           | ●              | ●      |
| Qi Wireless Charging:                    | The Qi wireless charging tray is located on the central console allowing for wireless charging of your smartphone (where available)  | -                   | ●           | ●              | ●      |
| Apple CarPlay® & Android Auto™           | In-car assistant systems that let you access certain features of your phone through Mazda Connect. Touch-screen functionality when vehicle is stationary   | Wired connection    | ●           | -              | -      |
|  |  | Wireless connection | -           | ●              | ●      |

● = Standard equipment, - = Not available.

Specification and naming conventions are subject to change.

<sup>1)</sup>Google Assistant, Google Maps and Google Play will be available for a free period of three (3) years, starting from the date of first registration of the new vehicle. To use other apps downloaded on the Google Play Store, you need to connect a smartphone with compatible iOS or Android operating system and a SIM card with data package from a mobile service provider to your vehicle. Additional costs may occur. Available apps depend on country. During and after the free period you can also use Google Assistant, Google Maps and Google Play, via connecting your vehicle with a smartphone with compatible iOS or Android operating system and a SIM card with data package from a mobile service provider. Additional costs may occur. Please note: To use Google Assistant, Google Maps and Google Play in your vehicle it is necessary to agree to the Google Terms of Service. Google, Android, Google Play and Google Maps are trademarks of Google LLC. Availability may vary by device, country and language.

<sup>2)</sup>Connected Services is a subscription service and requires a compatible mobile device to download and sign-up to the MyMazda App. A 7-year complimentary period is included and commences from the date of first registration of the vehicle.

|   |  | PRIME-LINE | CENTRE-LINE | EXCLUSIVE-LINE | HOMURA |
|---|--|------------|-------------|----------------|--------|
| <b>COMFORT AND CONVENIENCE</b><br>Air-conditioning: | Dual zone climate-controlled air-conditioning  | ●          | -           | -              | -      |
|   | Dual zone climate-controlled air-conditioning with rear air vents.   | -          | ●           | ●              | ●      |
| Cruise Control:                                     | Mazda Radar Cruise Control (MRCC) - A radar watches for traffic ahead and once the system senses a vehicle in front, the car will slow down and speed up automatically maintaining the drivers pre-set distance. Features Stop & Go, Curve speed control, Overtaking control and Landmark speed control functions  | ●          | ●           | ●              | ●      |
|   | Cruising & Traffic Support (CTS) with Lane Change Assist (LCA) - Where conditions allow, assists driver with accelerator, brake and steering functions when following a vehicle ahead in heavy traffic, helping to reduce driver fatigue. Lane change assist will assist the driver with the steering operation when changing lanes by the driver operating the vehicle indicator. | ●          | ●           | ●              | ●      |
| Electric windows:                                   | Front & rear with one-touch auto down / up   | ●          | ●           | ●              | ●      |
| Engine Start / Stop button                          |  | ●          | ●           | ●              | ●      |
| Head-up Display:                                    | Windscreen Projected colour Active Driving Display: Projects full-colour information directly onto the windscreen within the driver's line of sight, including navigation, speed and vehicle status.   | -          | ●           | ●              | ●      |
| Interior Lighting:                                  | Front LED illumination with spot lamp  | ●          | ●           | ●              | ●      |
|   | Rear LED illumination  | ●          | ●           | -              | -      |
|   | Rear LED illumination with spot lamp   | -          | -           | ●              | ●      |
|   | Top-down centre console illumination with front footwell lighting  | -          | -           | -              | ●      |
|   | Ambient lighting - The front upper door trims are equipped with ambient lighting, providing a choice of seven colours to help create your preferred interior cabin ambience.   | -          | -           | -              | ●      |
| Luggage compartment:                                | LED illumination   | ●          | ●           | ●              | ●      |
| Mi-DRIVE:   | Normal mode: achieves the optimum balance between fuel efficiency and driving performance.   | ●          | ●           | ●              | ●      |
|   | Sport mode: maximises responsiveness. It increases vehicle response when the accelerator pedal is depressed and accelerates powerfully.  | ●          | ●           | ●              | ●      |
|   | Off-road mode (AWD models only): maximises running performance. It prevents the drive wheels from spinning during off-road driving and improves the running performance. Use Off-road mode when driving on slippery roads such as muddy, sandy, or deep-snowy roads.   | -          | -           | ●              | ●      |
| Sun visors:   | Driver's and front passenger's with vanity mirror and driver's ticket holder   | ●          | -           | -              | -      |
|   | Driver's and front passenger's with illuminated vanity mirror and driver's ticket holder   | -          | ●           | ●              | ●      |

● = Standard equipment, - = Not available.

Specification and naming conventions are subject to change.

# EQUIPMENT

|  |  | PRIME-LINE | CENTRE-LINE | EXCLUSIVE-LINE | HOMURA |
|--|--|------------|-------------|----------------|--------|
| <b>SAFETY AND SECURITY</b>   |  |            |             |                |        |
| Airbags:   | Single stage front driver & passenger  | ●          | ●           | ●              | ●      |
|  | Front and rear side airbags  | ●          | ●           | ●              | ●      |
|  | Front central airbag   | ●          | ●           | ●              | ●      |
|  | Front and rear curtain airbags   | ●          | ●           | ●              | ●      |
|  | Front driver knee airbag   | ●          | ●           | ●              | ●      |
|  | Passenger airbag deactivation system (auto switch)   | ●          | ●           | ●              | ●      |
| Anti-lock Braking System (ABS)   |  | ●          | ●           | ●              | ●      |
| Dynamic Stability Control (DSC)  |  | ●          | ●           | ●              | ●      |
| e-Call with GPS:   | In the case of an accident, either provides a manual or automated message to the emergency services, which includes the vehicle's location. (European locations only)  | ●          | ●           | ●              | ●      |
| Emergency Stop Signalling system (ESS)                                       |  | ●          | ●           | ●              | ●      |
| Emergency tyre repair kit  |  | ●          | ●           | ●              | ●      |
| Hill Descent Control (AWD models only):                                      | Hill Descent Control supports safe downhill driving on steep slopes with slippery, rough road surfaces such as off-road terrain or snow-covered hills. It does this by automatically keeping the car at a constant speed without the driver needing to operate the brakes.   | -          | -           | ●              | ●      |
| Hill Launch Assist (HLA):  | When taking off on an incline, helps prevent the car from rolling backwards when the driver moves their foot from the brake to the accelerator pedal.  | ●          | ●           | ●              | ●      |
| i-ACTIVSENSE:  | <b>Blind Spot Monitoring (BSM) with Rear Cross Traffic Alert (RCTA)</b>  | ●          | ●           | ●              | ●      |
|  | <b>Emergency Lane Keeping</b> - Features four advanced driver assistance systems designed to help prevent lane and road departures (Lane Keep Assist and Road Keep Assist) and reduce the risk of collisions with surrounding vehicles (Blind Spot Assist and Head-On Traffic Avoidance Assist).   | ●          | ●           | ●              | ●      |
|  | <b>Front Cross Traffic Alert (FCTA)</b> - When pulling out of junctions, the system checks for approaching vehicles in your blind spots either side or the front of your vehicle. When an oncoming vehicle is detected, it sounds a warning and applies the brakes if the system believes a collision may occur.   | ●          | ●           | ●              | ●      |
|  | <b>Intelligent Speed Assistance (ISA)</b> - A driver operated speed-limiting system that works in conjunction with Traffic Sign Recognition (TSR) to help keep drivers from exceeding the speed limit unintentionally.   | ●          | ●           | ●              | ●      |
|  | <b>Lane Departure Warning System (LDWS)</b> - The system detects the line markings on the road surface and instantly warns you in case of unintentional lane departure.  | ●          | ●           | ●              | ●      |
|  | <b>Proactive Driving Support (PDS)</b> - The PDS system supports the driver by assisting with braking when a vehicle or motorcycle is detected ahead. Upon releasing the accelerator pedal, the system applies partial braking to help prevent the vehicle from approaching too closely to the one in front.   | ●          | ●           | ●              | ●      |
|  | <b>Smart Brake Support (SBS)</b> – Helps drivers avoid or reduce the severity of collisions by monitoring traffic and surroundings and applying brakes when needed. Includes:<br>- Turn-Across Traffic: Assists in preventing frontal collisions when turning across traffic.<br>- Head-On Collision Mitigation: Detects if an oncoming vehicle may drift into your lane and applies early braking to reduce impact.<br>- Intersection Accident Avoidance: Warns the driver and, if necessary, brakes to prevent collisions when turning at junctions.<br>- Low-Speed Object Detection (Front & Rear): Helps avoid collisions with slow-moving or stationary objects at low speeds.<br>- Front Crossing Assist: Detects vehicles or motorcycles crossing ahead at junctions and applies braking to avoid or lessen impact. | ●          | ●           | ●              | ●      |
|  | <b>Traffic Sign Recognition (TSR)</b> with intelligent speed assist - Utilising the front sensing camera and Navigation data, this system is designed to notify the driver of traffic signs by displaying them on the instrument panel and the head-up display. If the vehicle exceeds the recognised speed limit, an audible tone will be activated.  | ●          | ●           | ●              | ●      |
|  | <b>Vehicle exit warning</b> - Assists the driver in checking the rear of the vehicle when exiting the vehicle. When a vehicle or bicycle approaching from the rear is detected, various screen displays and warning sounds notify the driver of the danger.  | ●          | ●           | ●              | ●      |
| ISOFIX child seat anchorage; attached to outer rear seats                    |  | ●          | ●           | ●              | ●      |
| Mazda Co-Pilot Concept:  | <b>Driver Attention Alert (DAA)</b> - The system monitors driver inputs and the vehicle's movements to sense the early stages of driver fatigue.   | ●          | ●           | ●              | ●      |
|  | <b>Driver Emergency Assist (DEA)</b> - Helps minimise collision risk and damage by automatically slowing or stopping the vehicle if the driver becomes unable to drive due to a sudden illness or loss of responsiveness.  | ●          | ●           | ●              | ●      |
|  | <b>Driver Monitoring (DM)</b> - A camera monitors the driver's facial movements to detect driver fatigue, encouraging the driver to take a rest where needed.  | ●          | ●           | ●              | ●      |
| Rear Seat Alert:   | The Rear Seat Alert is a system that reminds the driver to check if any occupants or luggage have been left behind on the rear seats   | ●          | ●           | ●              | ●      |
| Remote central locking with deadlocking and automatic door lock when driving |  | ●          | ●           | ●              | ●      |
| Smart keyless entry:   | Allows opening and locking of the vehicle without removing the key from your pocket or bag   | -          | ●           | ●              | ●      |
| Seatbelt reminder audible warning:   | Driver, passenger and rear seats   | ●          | ●           | ●              | ●      |
| Thatcham accredited alarm and immobiliser                                    |  | ●          | ●           | ●              | ●      |
| Tyre Pressure Monitoring System (TPMS)                                       |  | ●          | ●           | ●              | ●      |

● = Standard equipment, - = Not available.

Specification and naming conventions are subject to change.

# TECHNICAL INFORMATION

| Model Availability | 2.5 e-SKYACTIV MHEV 2WD<br>141ps Automatic | 2.5 e-SKYACTIV MHEV AWD<br>141ps Automatic |
|--------------------|--|--|
| Prime-Line         | ●  | -  |
| Centre-Line        | ●  | -  |
| Exclusive-Line     | ●  | ●  |
| Homura             | ●  | ●  |

## Dimensions

|  |   |
|--|---|
| Overall length / width <sup>1)</sup> / height (mm) <sup>2)</sup> | 4,690 / 1,860 (2,077) / 1,690                       |
| Wheelbase (mm)   | 2,815   |
| Ground clearance between the axles (mm) - unladen                | 205   |
| Front track / Rear track (mm)                                    | 1,605 / 1,625                                       |
| Front headroom <sup>3)</sup> / leg room / shoulder room (mm)     | 1,007 (996) / 1,058 / 1,462                         |
| Rear headroom <sup>3)</sup> / leg room / shoulder room (mm)      | 1,020 (992) / 1,012 / 1,412                         |
| Cargo volume, acc. to VDA (l):                                   | 583   |
|  | 2-seat mode to ceiling including underfloor storage |
|  | 2,019   |
| Brake Type - Front & Rear  | Ventilated Disc / Solid Disc                        |
| Brake Dimensions - Front / Rear (mm)                             | 328 / 325   |

## Steering

|                                 |   |
|---------------------------------|---|
| Steering gear                   | Electric Power Steering (Rack and Pinion) |
| Wall to Wall turning circle (m) | 12.0                                      |

<sup>1)</sup> Vehicle width excludes mirrors. Figures in brackets includes mirrors opened.

<sup>2)</sup> Values include driver at 75kg, height includes roof rails.

<sup>3)</sup> Figures in brackets are for vehicles fitted with panoramic sunroof.

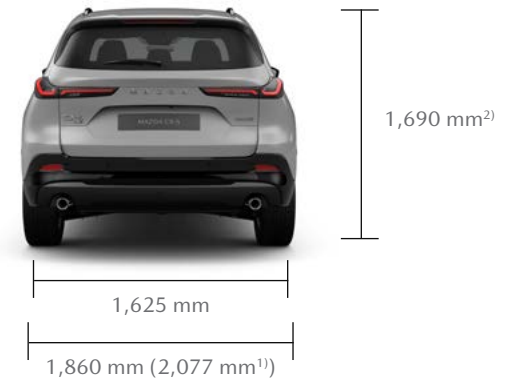
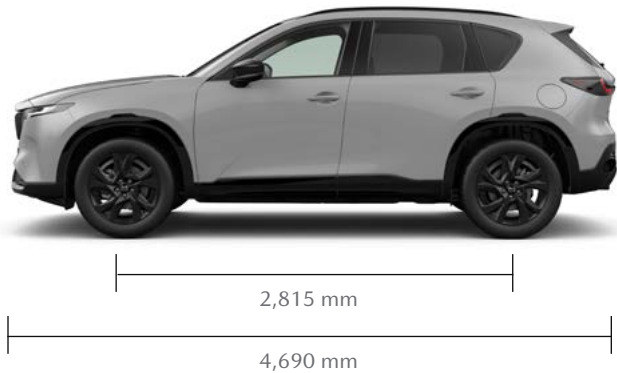

# TECHNICAL INFORMATION

|   |                     | 2.5 e-SKYACTIV MHEV 2WD<br>141ps Automatic | 2.5 e-SKYACTIV MHEV AWD<br>141ps Automatic |
|---|---------------------|--|--|
| <b>Engine</b>                                       |                     |  |  |
| Displacement (cc)                                   |                     | 2488                                       | 2488                                       |
| Bore x Stroke (mm)                                  |                     | 89.0 x 100.0                               | 89.0 x 100.0                               |
| Valves per cylinder                                 |                     | 4  | 4  |
| Compression ratio                                   |                     | 13:1                                       | 13:1                                       |
| Transmission  |                     | 6-Speed Automatic                          | 6-Speed Automatic                          |
| <b>Fuel Saving Technology</b>                       |                     |  |  |
| i-stop system                                       |                     | ●  | ●  |
| Mazda M Hybrid 24-volt battery                      |                     | ●  | ●  |
| Cylinder deactivation                               |                     | ●  | ●  |
| <b>Performance</b>                                  |                     |  |  |
| Maximum power output                                | Total ps (KW) / rpm | 141 (103) / 4,500-5,000                    | 141 (103) / 4,500-5,000                    |
| Max. torque (Nm / rpm)                              |                     | 238/3,500-3,750                            | 238/3,500-3,750                            |
| Acceleration (0-62 mph in seconds)                  |                     | 10.5                                       | 10.9                                       |
| Top Speed (mph)                                     |                     | 116  | 115  |
| <b>Fuel Economy and CO<sub>2</sub> Emissions</b>    |                     |  |  |
| WLTP fuel consumption mpg (l/100km) <sup>1)</sup>   | Low                 | 30.1 (9.4) - 30.7 (9.2)                    | 27.2 (10.4) - 27.4 (10.3)                  |
|   | Medium              | 41.5 (6.8) - 42.2 (6.7)                    | 39.2 (7.2) - 39.8 (7.1)                    |
|   | High                | 47.1 (6.0) - 47.9 (5.9)                    | 44.8 (6.3)                                 |
|   | Extra High          | 39.2 (7.2)                                 | 37.2 (7.6) - 37.7 (7.5)                    |
|   | Combined            | 40.4 (7.0)                                 | 37.7 (7.5) - 38.2 (7.4)                    |
| WLTP CO <sub>2</sub> emissions <sup>1)</sup> (g/km) |                     | 157 - 159                                  | 168 - 169                                  |
| EC emission level                                   |                     | Euro Stage 6d                              | Euro Stage 6d                              |
| Recommended fuel                                    |                     | Unleaded 95 RON                            | Unleaded 95 RON                            |
| Fuel tank capacity (litres)                         |                     | 56   | 58   |
| <b>Weights</b>                                      |                     |  |  |
| Minimum Kerb weight (kg) excl. driver               |                     | 1,629 / 1,687                              | 1,671 / 1,711                              |
| Maximum Kerb weight (kg) incl. driver (75kg)        |                     | 1,708 / 1,786                              | 1,786 / 1,827                              |
| Permitted gross vehicle weight (kg)                 | Total               | 2,230                                      | 2,272                                      |
|   | Front/rear          | 1,170 / 1,060                              | 1,182 / 1,090                              |
| Towing limit (kg) <sup>2)</sup> :                   | Braked              | 2,000                                      | 2,000                                      |
| Maximum roof load (kg)                              |                     | 85   | 85   |

<sup>1)</sup> Figures shown are for comparability purposes; only compare fuel consumption and CO<sub>2</sub> figures with other cars tested to the same technical procedures.

These figures may not reflect real life driving results, which will depend upon a number of factors including the accessories fitted (post-registration), variations in weather, driving styles and vehicle load. There is a new test used for fuel consumption and CO<sub>2</sub> figures. The CO<sub>2</sub> figures shown however, are based on the outgoing test cycle and will be used to calculate vehicle tax on first registration.

<sup>2)</sup> Towing capacity is based on a 12% gradient and tested in accordance with 92/21/EEC as amended by 95/48/EC.

## SKYACTIV ENGINE TECHNOLOGIES

### **2.5-LITRE e-SKYACTIV G: POWER MEETS EFFICIENCY**

Mazda's 2.5-litre e-Skyactiv G engine embodies our 'right-sizing' philosophy—where increased engine capacity creates a larger combustion chamber for a more efficient and powerful combustion process. The result? Lower emissions without compromising performance, delivering impressive torque for a truly engaging drive.

The 141ps e-Skyactiv G powertrain in the Mazda CX-5 is a highly efficient, direct-injection petrol engine, tuned for smooth, responsive acceleration in everyday driving—whether navigating city streets, winding country roads, or cruising the motorway. Behind the wheel, you'll experience Mazda's signature sense of oneness with the car.

Thanks to high-compression combustion and intelligent features like cylinder deactivation, the 2.5-litre engine offers excellent fuel economy. At constant speeds, it seamlessly switches between two-cylinder and four-cylinder operation, reducing fuel consumption without affecting performance. Because this advanced engineering is so precise and smooth, and you'll only notice the benefits of greater efficiency you enjoy its spirited driving performance.

### **MAZDA M HYBRID: SMARTER EFFICIENCY EVERY DRIVE**

Mazda M Hybrid is our innovative approach to hybrid technology, designed to make every journey more efficient. Using four key components, it captures energy normally lost during braking and stores it in a 24V lithium-ion battery. This energy is then used to assist the engine and power the car's electrical systems—helping you travel further on a single tank while reducing CO<sub>2</sub> emissions and other particulates.

The Mazda CX-5 features this advanced technology as standard, delivering outstanding performance, lower running costs and strong environmental credentials—all without compromising the driving experience you love.



## SKYACTIV-VEHICLE DYNAMICS: TRANSMISSIONS, CHASSIS AND BODY



### TRANSMISSIONS

Mazda's advanced 6-speed Skyactiv-Drive automatic transmission combines the best qualities of CVT, dual-clutch and conventional automatic systems to deliver a truly refined driving experience.

With smooth, seamless gear changes and a direct, responsive feel, Skyactiv-Drive ensures every journey feels controlled and composed. This intelligent design not only enhances driving confidence but also contributes to excellent fuel economy—so you can enjoy performance without compromise.

Whether navigating city streets or cruising on the motorway, Skyactiv-Drive works in harmony with Mazda's Jinba-Ittai philosophy, creating a sense of unity between car and driver for effortless control and pure driving enjoyment.



### SKYACTIV-CHASSIS

Every journey in the Mazda CX-5 begins with a chassis designed for harmony and balance. Lightweight yet robust, it delivers the essence of Mazda's 'Jinba-Ittai' philosophy—creating a seamless connection between car and driver.

Fine-tuned for precision, the chassis offers agile handling at low and medium speeds, while maintaining reassuring stability on the motorway. The result is a drive that feels effortless and engaging, whether you're navigating city streets, exploring scenic country roads, or enjoying the freedom of the open highway. This is driving as it should be—responsive, refined, and deeply rewarding.



### SKYACTIV-BODY

For a car to excel at its core functions—accelerating, turning and stopping—it needs a body that is both lean and robust.

Crafted with a light yet rigid structure, the CX-5 delivers exceptional agility for dynamic handling, while ensuring uncompromising safety for you and your passengers. This means every journey feels secure, refined and effortlessly enjoyable—whether you're navigating city streets, exploring scenic routes or embarking on a family road trip.

Mazda's approach brings peace of mind without sacrificing driving pleasure. It's a body built for confidence, comfort and control, embodying the pure essence of our philosophy: safe, joyful driving without compromise.

# ADVANCED SAFETY TECHNOLOGY

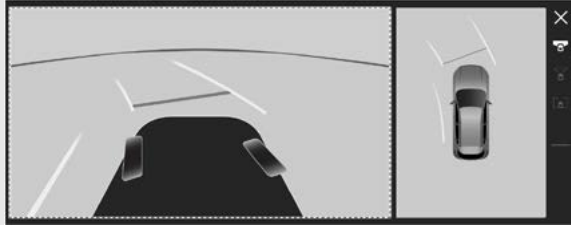

## 360° VIEW MONITOR WITH SEE-THROUGH VIEW

Enjoy a complete view of your surroundings with the 360° camera system, using front, side, and rear cameras to help you manoeuvre safely and reduce the risk of collisions.

Parking is effortless thanks to on-screen guidelines, while the innovative See-Through View feature gives a virtual look beneath the front or rear of the vehicle—helping you to identify potential hidden hazards.

(Standard on Exclusive-Line and Homura grades)

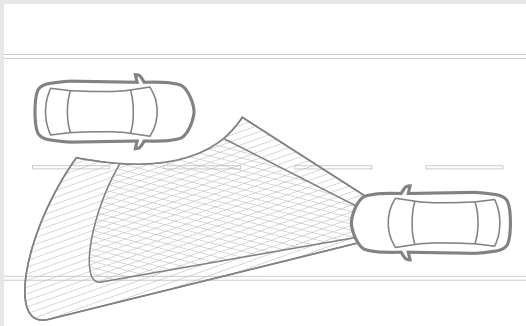

## ADAPTIVE LED HEADLIGHTS

Mazda's Adaptive LED Headlights deliver cutting-edge illumination for safer, stress-free driving at any time. By combining five advanced technologies, the system maximises visibility while reducing glare for others:

- Wide-range Low Beams – Illuminate a broader area at low speeds
- Marking Light – Highlights pedestrians for added safety
- Highway Mode – Extends visibility at higher speeds
- Glare-free High Beams – Automatically dim to prevent dazzling oncoming traffic
- Adaptive Front Lighting – Adjusts light direction based on steering and lane position

The result? Clearer vision, greater confidence and a more relaxed drive.

(Standard on Homura grades)



## i-ACTIV AWD

Whether you are on the motorway on a dark and rainy night or driving up a snowy country road, Mazda's all-wheel-drive system is designed to provide safety and comfort with fuel efficiency. Our engineers have developed i-ACTIV AWD to constantly monitor road conditions in real-time, watching for tiny variations in wheel speed that a driver would never notice. The system proactively controls the distribution of torque to all four wheels providing solid and predictable handling for all-road performance.

(Available on Exclusive-Line and Homura grades)

# ADVANCED SAFETY TECHNOLOGY

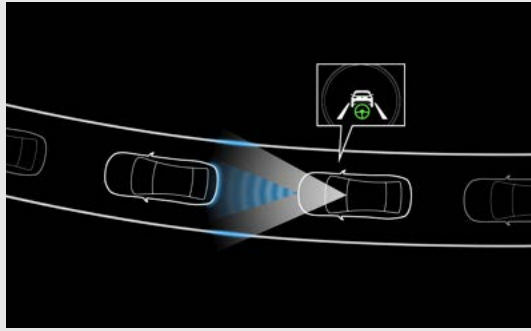

## CRUISING & TRAFFIC SUPPORT (CTS)

Automatically operates acceleration and braking to maintain a proper trailing distance between your Mazda and the vehicle ahead. In addition, it assists with steering operations to keep the car within its lane. CTS contributes to reducing driver fatigue, as well as supporting a safer, more reassuring and more comfortable driving experience.

(Standard across all grades)



## DRIVER EMERGENCY ASSIST

Mazda's Driver Emergency Assist System is designed to keep you and your passengers safe in unexpected situations. If the system detects that the driver is unable to continue driving—such as due to sudden illness—it automatically alerts occupants, activates hazard lights, and gently decelerates the vehicle to a controlled stop. Whether you're on a motorway, an A-road or a local street, this intelligent feature provides reassurance and confidence, helping reduce the risk of collisions and protecting what matters most.

(Standard across all grades)

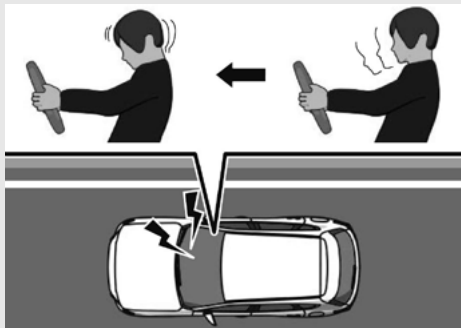

## DRIVER MONITORING

Detects sleepiness or inattention by monitoring changes in expression or movement of the driver's line of sight. A camera and infrared LED monitor the driver's condition both day and night. If the system determines that the driver has fallen asleep or is inattentive, it sounds an alert to make the driver aware while also setting up for automatic braking to help prepare for a potential incident.

(Standard across all grades)

# ADVANCED SAFETY TECHNOLOGY

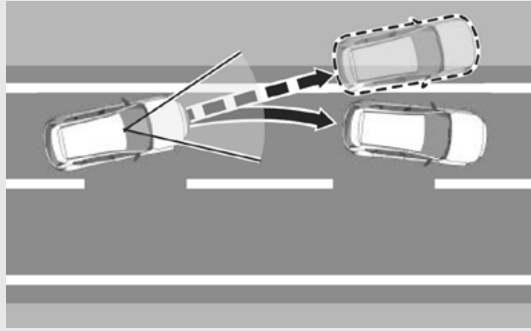

## EMERGENCY LANE KEEPING

Mazda's Emergency Lane Keep system is designed to give you extra confidence on every journey by actively assisting steering to help avoid danger. It combines four advanced features:

- Lane-keep Assist – Helps maintain your position within the lane
- Road Keep Assist – Prevents departure from the road with alerts and gentle steering corrections
- Blind Spot Assist – Reduces the risk of collisions when changing lanes by intervening if another vehicle is detected
- Head-on Traffic Avoidance Assist – Assists steering to avoid potential collisions with oncoming traffic

Together, these intelligent technologies provide reassurance and peace of mind, so you can enjoy a safer, more relaxed drive—whether commuting, travelling with family, or exploring new roads.

(Standard across all grades)

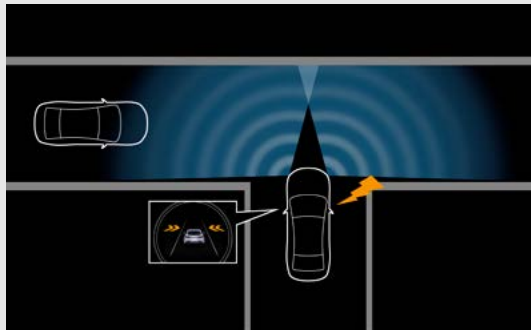

## FRONT CROSS TRAFFIC ALERT

Front Cross Traffic Alert gives you added confidence at junctions with restricted views, one of the most common accident points. Using advanced radar sensors, the system monitors blind spots to the front left and right, detecting vehicles approaching from either side. If a potential hazard is identified, clear visual and audible alerts warn you in time to react—helping to reduce the risk of collisions and making every turn safer.

(Standard across all grades)

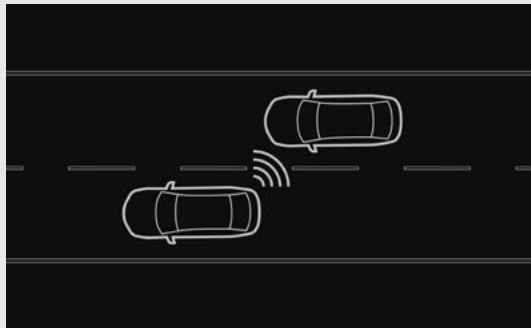

## BLIND SPOT MONITORING (BSM) WITH REAR CROSS TRAFFIC ALERT (RCTA)

BSM uses radars mounted in the rear bumper to detect vehicles approaching from behind and in the adjacent lane. It alerts the driver to the presence of vehicles in the blind spot on either side by displaying an icon in the appropriate door mirror. If the driver indicates to change lanes with a vehicle in the blind spot, the icon flashes and a warning beep is sounded. RCTA is designed to help you make sure it's safe to start backing up. The system uses the same radars and indicators as BSM to watch for vehicles coming from both sides and alerts the driver when they come near.

(Standard across all grades)

# ADVANCED SAFETY TECHNOLOGY



## MAZDA DRIVER PERSONALISATION SYSTEM

The Mazda Driver Personalisation System recognises the driver using the camera inside the vehicle and automatically restores various driver settings that have been stored. This includes a function that automatically adjusts the driver's seat, Active Driving Display and outer mirror angle based on the driver's physique. The system will also move the seat so that the driver can easily enter and exit the vehicle more easily.

(Standard on Homura grade)



## PROACTIVE DRIVING SUPPORT

Designed to make driving smoother and safer, especially on busy roads or long trips. When you lift off the accelerator, the system gently helps with braking to maintain a safe distance from the vehicle ahead—reducing stress and driver fatigue. This intelligent support means greater peace of mind and added confidence when travelling long distances by easing the workload in stop-and-go traffic and unpredictable conditions.

(Standard across all grades)

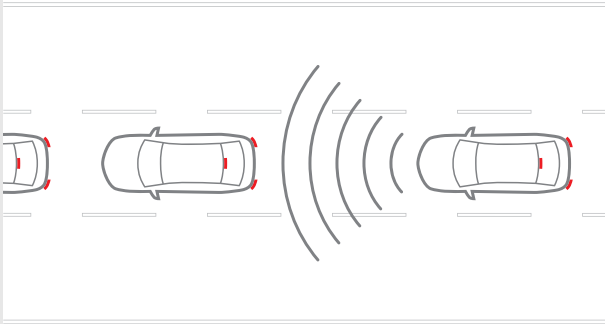

## SMART BRAKE SUPPORT

Mazda's Smart Brake Support system is designed to help prevent collisions and reduce impact when the unexpected happens. Using advanced sensors and cameras, SBS monitors vehicles, pedestrians and obstacles around you—providing timely alerts and, if necessary, applying the brakes automatically to avoid or minimise a collision.

From busy junctions to motorway traffic, SBS offers intelligent features like Turn-Across Traffic, Front Crossing, and Head-on Collision Mitigation, as well as low-speed detection for parking and reversing. This means greater confidence and peace of mind for you and your passengers, wherever the road takes you.

(Standard across all grades)

# VEHICLE TAX RATES

## VEHICLE TAX RATES TAX YEAR 2026-27

| CO <sub>2</sub> EMISSIONS<br>FIGURE (G/KM) | ALL CARS<br>FIRST YEAR RATE | ALL CARS STANDARD RATE<br>(12 months) |
|--|-----------------------------|---------------------------------------|
| 0  | £10                         | £200                                  |
| 1-50                                       | £115                        | £200                                  |
| 51-75                                      | £135                        | £200                                  |
| 76-90                                      | £280                        | £200                                  |
| 91-100                                     | £365                        | £200                                  |
| 101-110                                    | £405                        | £200                                  |
| 111-130                                    | £455                        | £200                                  |
| 131-150                                    | £560                        | £200                                  |
| 151-170                                    | £1,410                      | £200                                  |
| 171-190                                    | £2,270                      | £200                                  |
| 191-225                                    | £3,420                      | £200                                  |
| 226-255                                    | £4,850                      | £200                                  |
| Over 255                                   | £5,690                      | £200                                  |

First-year rate is paid when first registering a vehicle and is for the first 12 months Vehicle Excise Duty. After the first 12 months, the standard rate applicable at that time is payable. Petrol/diesel/alternative fuel cars with a list price >£40k will be subject to a premium of £440 over the Standard Rate for 5 years from the start of the second licence.

## WARRANTY

All Mazda cars registered from 1st September 2025 will benefit from a six-year manufacturer's warranty, or 100,000 miles, whichever comes first.

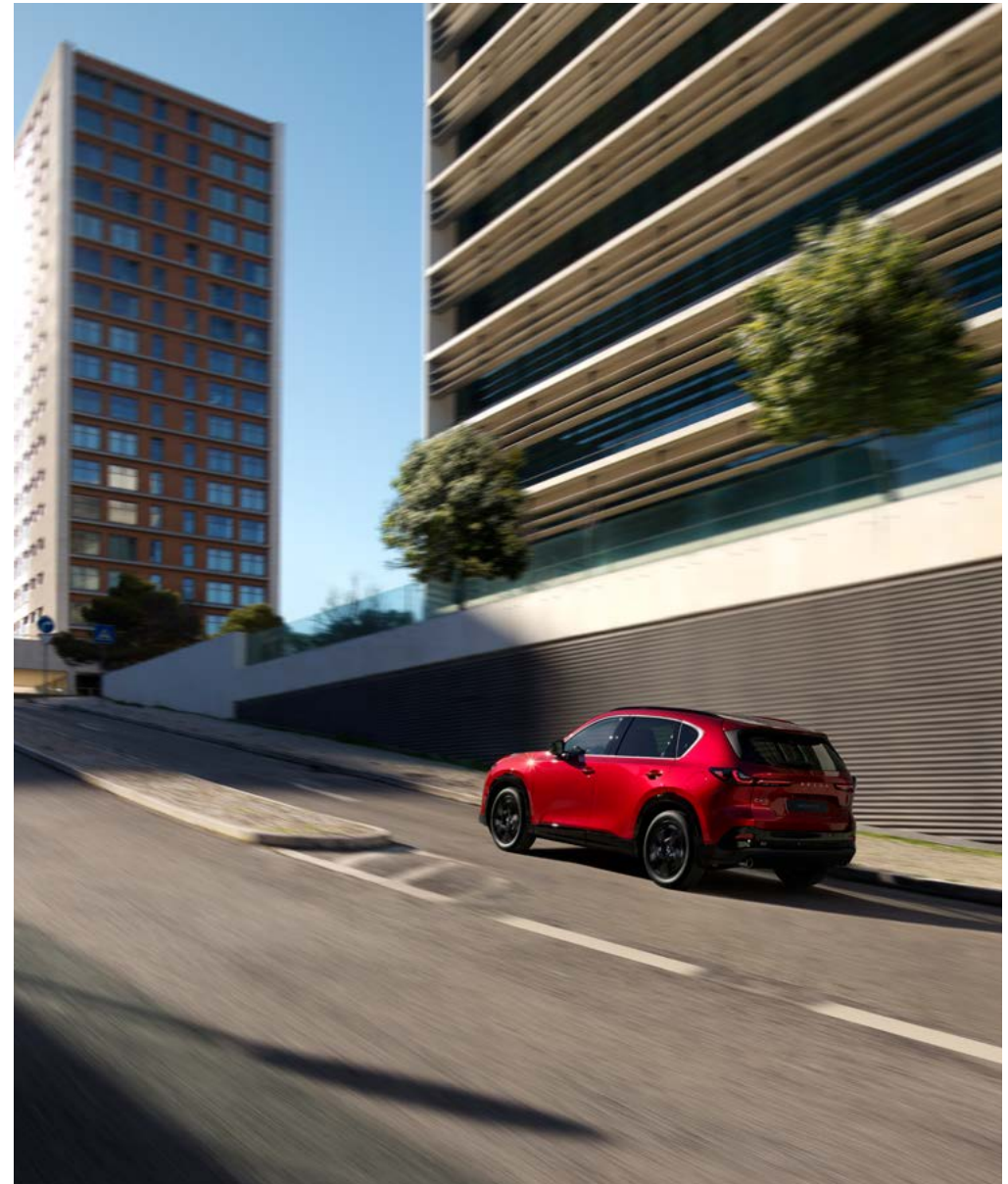

# MAZDA SERVICES

The maximum service interval for your Mazda is 12,500 miles or 12 months whichever occurs first, however, the servicing intervals may reduce based on the style of driving and the conditions under which your vehicle is operated.



## MAZDA FINANCIAL SERVICES

Mazda Financial Services offers a variety of finance and insurance products to suit the needs of both private and business customers. With our wide range of plans and services, no-one is more committed to delivering complete motoring confidence and total peace of mind than Mazda and Mazda Financial Services.†



## MAZDA CAR INSURANCE

When Mazda Car Insurance is a fully comprehensive monthly subscription policy with no hidden fees – change your details, renew or cancel, without any charges. You can set up and manage your policy online anytime, anywhere. In just a few clicks, changes are applied immediately, meaning no waiting for paperwork, estimates or call centres. Plus, your price is guaranteed for 12 months if everything stays the same.

Enjoy benefits such as the use of a Mazda Approved Accident Repair Centre, Mazda Genuine Parts, a courtesy car, uninsured driver cover, UK accident recovery, and more.

Find out more at [www.mazdamotorinsurance.co.uk](http://www.mazdamotorinsurance.co.uk)

Mazda Car Insurance is arranged and administered by Wrisk Transfer Limited, registered in England and Wales No. 10657213 at 45 Gresham Street, London, EC2V 7BG and authorised and regulated by the Financial Conduct Authority, Firm Reference No. 788062. Please read the policy wording for full terms, conditions, exclusions and excesses.



## FREE MAZDA ACCIDENT AFTERCARE

In the event of an accident, Call Mazda First 0800 015 0367 before your insurer for free 24-hour Accident AfterCare and to redeem your £250 Excess Return voucher. Our dedicated case handlers will liaise with your insurer and arrange Mazda Genuine Parts and repairs at a Mazda Approved Bodyshop, keeping your Mazda 100% Mazda and maintaining your Mazda warranties. We'll also provide accident recovery if your Mazda isn't driveable and a free courtesy car during the repair. Terms and conditions apply.

Save 0800 015 0367 to your mobile phone.

### TAX FREE – DIPLOMATIC AND MILITARY SALES

For further information contact your Mazda dealer or contact Mazda on 03457 48 48 48.

### MOTABILITY

For all Motability enquiries please contact your Mazda dealer or contact Mazda on 03457 48 48 48.



## MAZDA DRIVEAWAY INSURANCE

Benefit from up to 5 days free cover when you buy a new or used Mazda from an authorised Mazda Dealer - you'll also get a quote for Mazda Car Insurance.

Find out more at [www.mazdamotorinsurance.co.uk/driveaway](http://www.mazdamotorinsurance.co.uk/driveaway)

This price list, dated 1 April 2026, supersedes all previous price lists. It includes changes to Vehicle Excise Duty as confirmed in the Autumn 2025 budget affecting recommended 'On the Road' prices. Final prices shown are recommended 'On the Road' prices and are inclusive of number plates, 12 months' Vehicle Excise Duty and first registration fee. Certain models may be subject to changes in CO<sub>2</sub> emission levels and Vehicle Excise Duty Bands. Due to ongoing updates the specification (including fuel consumption, CO<sub>2</sub> emissions and equipment) of the vehicle you order and receive may be different to that detailed in this guide. Please speak to your dealer for the latest information. Images may not be to UK specification. †Subject to status to over 18s. Indemnities may be required. Terms apply. Mazda Financial Services.

# STAY IN TOUCH WITH MAZDA CX-5

Visit our website and use the Configurator to create your perfect version of the Mazda CX-5.



**BUILD YOUR MAZDA CX-5**



FOLLOW US ON



# CRAFTED WITH JAPANESE SOUL

APRIL 2026

Mazda Motors UK reserves the right to introduce changes in specification and equipment due to its ongoing product development. Prices are subject to change without prior notice. Colour and trim samples shown in this digital brochure may vary from the actual colours because of the variations of resolutions and colours found in various screen displays, and if printed, limitations within the printing process. Models shown may not be to UK specification. It is recommended that you consult your Mazda dealer when referring to these. Apple CarPlay®, Android Auto™ and Bose are registered trademarks in the U.S. and other countries. Used with permission. The Bluetooth® word mark and logos are owned by the Bluetooth SIG, Inc. and any use of such marks by Mazda Motor Company is under licence. Other trademarks and trade names are those of their respective owners.

Google built-in: Google Assistant, Google Maps and Google Play will be available for a free period of three (3) years, starting from the date of first registration of the new vehicle. To use other apps downloaded on the Google Play Store, you need to connect a smartphone with compatible iOS or Android operating system and a SIM card with data package from a mobile service provider to your vehicle. Additional costs may occur. Available apps depend on country. During and after the free period you can also use Google Assistant, Google Maps and Google Play, via connecting your vehicle with a smartphone with compatible iOS or Android operating system and a SIM card with data package from a mobile service provider. Additional costs may occur. Please note: To use Google Assistant, Google Maps and Google Play in your vehicle it is necessary to agree to the Google Terms of Service. Google, Android, Google Play and Google Maps are trademarks of Google LLC. Availability may vary by device, country and language.