



> Keep me updated



> Find a Retailer



> View the Range Guide

EQC



Effective from December 2019 Production

Mercedes-Benz





> Keep me updated



> Find a Retailer



> View the Range Guide

Contents

7 Model lines

19 Introducing MBUX

20 Mercedes me connect

23 Charging while at home -
BP Chargemaster Homecharge

24 Model prices

25 Option packages

26 Colours and materials

30 Wheels

32 Standard equipment

35 Optional equipment

36 Technical data

40 Road Fund Licence

41 Services and insurance

42 Mercedes-Benz Finance



> Keep me updated



> Find a Retailer



> View the Range Guide

3



Some of the model features, optional extras and colours shown may not be available, or may only be available in a different specification.



> Keep me updated



> Find a Retailer



> View the Range Guide



Some of the model features, optional extras and colours shown may not be available, or may only be available in a different specification.



> Keep me updated



> Find a Retailer



> View the Range Guide



Some of the model features, optional extras and colours shown may not be available, or may only be available in a different specification.

MENU

REAR





> Keep me updated



> Find a Retailer



> View the Range Guide



Some of the model features, optional extras and colours shown may not be available, or may only be available in a different specification.



> Keep me updated



> Find a Retailer



> View the Range Guide

Sport



Black panel radiator grille with louvres and surround in chrome, mirror caps in high-gloss black, front and rear bumper with insert in black



> Keep me updated



> Find a Retailer



> View the Range Guide



Multibeam LED headlights



Model lines | Sport

8

MBUX-system including 10.25-inch instrument display and 10.25-inch media display with touchscreen



Front and rear LED light band



ARTICO dashboard, multifunction steering wheel in nappa leather, aluminium trim with high-gloss centre console



> Keep me updated



> Find a Retailer



> View the Range Guide

The new EQC marks another milestone in electric driving. It combines the style and practicality of an SUV with outstanding performance and efficiency. The striking exterior features 19" 5-twin-spoke alloy wheels, a front and a rear LED light band, as well as multibeam LEDs with blue colour accents, echoed by the blue EQC badge on the wing. Inside, the Seat Comfort

package, Mercedes-Benz sound system and 64-colour ambient lighting create the perfect atmosphere. The MBUX multimedia system with 10.25-inch instrument display and 10.25-inch media display with touchscreen complete with EQ-tailored hard disk navigation services.

Exterior

- KEYLESS-GO Comfort package
- Mirror package
- 19" 5-twin-spoke alloy wheels
- Badge on the wing in high-gloss black with chrome stripes and blue 'EQC' lettering
- Black panel radiator grille with louvres and surround in chrome
- Exterior mirrors in high-gloss black
- Front and rear LED light band
- Front apron with high-gloss black inserts and lower bumper section in black
- MULTIBEAM LEDs with inner housing and tubes in high-gloss black plus stripes in blue
- Privacy glass

Interior

- Seat Comfort package – electro-pneumatic four-way lumbar support for driver and front passenger seat; manual seat cushion depth adjustment (6 cm)
- Ambient lighting
- Dashboard in ARTICO man-made leather with metallised-look finish and piping in rosé gold
- Floor mats
- Heated seats
- Steering wheel – 3-spoke multifunction steering wheel, trimmed in leather

Safety and Assistance Systems

- Active Park Assist with reversing camera
- Blind Spot Assist

Communications and In-Car Entertainment

- DAB digital radio tuner
- Hard disk navigation
- MBUX multimedia system with 10.25-inch instrument display and 10.25-inch media display with touchscreen
- Mercedes-Benz sound system

Trim and Upholstery

Light longitudinal-grain aluminium trim with high-gloss centre console



ARTICO man-made leather – black



ARTICO man-made leather – silk beige/black



OTR from £65,720 incl. VAT¹

¹The recommended on-the-road price includes the Road Fund Licence applicable to the standard model plus delivery charge (£715.00 incl. VAT), new vehicle registration fee (£55.00) and number plates (£25.00 incl. VAT). VAT is calculated at the standard rate of 20%



> Keep me updated



> Find a Retailer



> View the Range Guide

AMG Line





> Keep me updated



> Find a Retailer



> View the Range Guide



AMG radiator grille in high-sheen black, mirror caps in vehicle color



Model lines | AMG Line

11

Carbon fibre trim

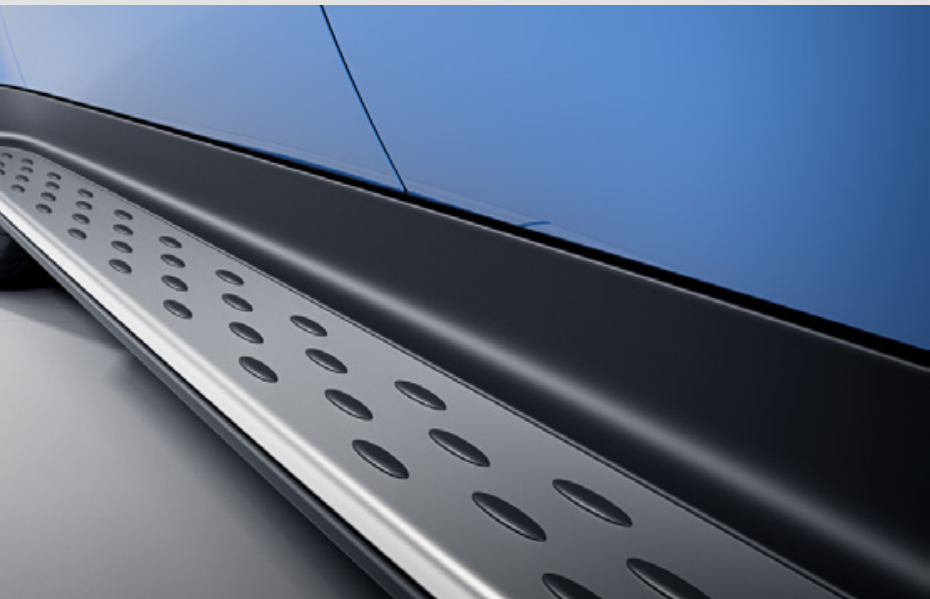

Running boards



Leather upholstery, ARTICO dashboard, flat-bottomed multifunction steering wheel in nappa leather



> Keep me updated



> Find a Retailer



> View the Range Guide

If you want to emphasise the sporty, stylish persona of the EQC, the AMG Line is the perfect choice. The front turns heads with its striking AMG radiator grille in high-sheen black. 20" AMG multi-spoke alloy wheels and aluminium running boards are also standard. The interior reflects the sporty character

with leather upholstery paired with an anthracite carbon fibre-look trim and high-gloss centre console. The multifunction steering wheel is finished in nappa leather, while the floor mats carry the bold AMG logo.

In addition/replacement to Sport:

Exterior

20" AMG multi-spoke alloy wheels

AMG-specific black panel radiator grille in a twin-blade design and surround in high-gloss black

AMG-specific front apron in a jet-wing design, air intakes with trim parts in chrome and inserts in high-gloss black, as well as visible and air curtains

AMG-specific rear apron with visible air outlets, diffuser insert in black and trim element in chrome

Running boards

Interior

AMG brushed stainless steel sports pedals with black rubber studs

AMG floor mats

AMG sports seats in leather

Trim and Upholstery

Anthracite carbon fibre-look trim with high-gloss centre console

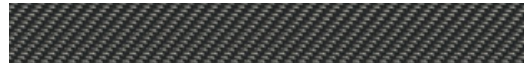

Leather – black



OTR from £67,715 incl. VAT¹
Upgrade price from Sport £1,995

¹The recommended on-the-road price includes the Road Fund Licence applicable to the standard model plus delivery charge (£715.00 incl. VAT), new vehicle registration fee (£55.00) and number plates (£25.00 incl. VAT). VAT is calculated at the standard rate of 20%



> Keep me updated



> Find a Retailer



> View the Range Guide

AMG Line Premium





> Keep me updated



> Find a Retailer



> View the Range Guide

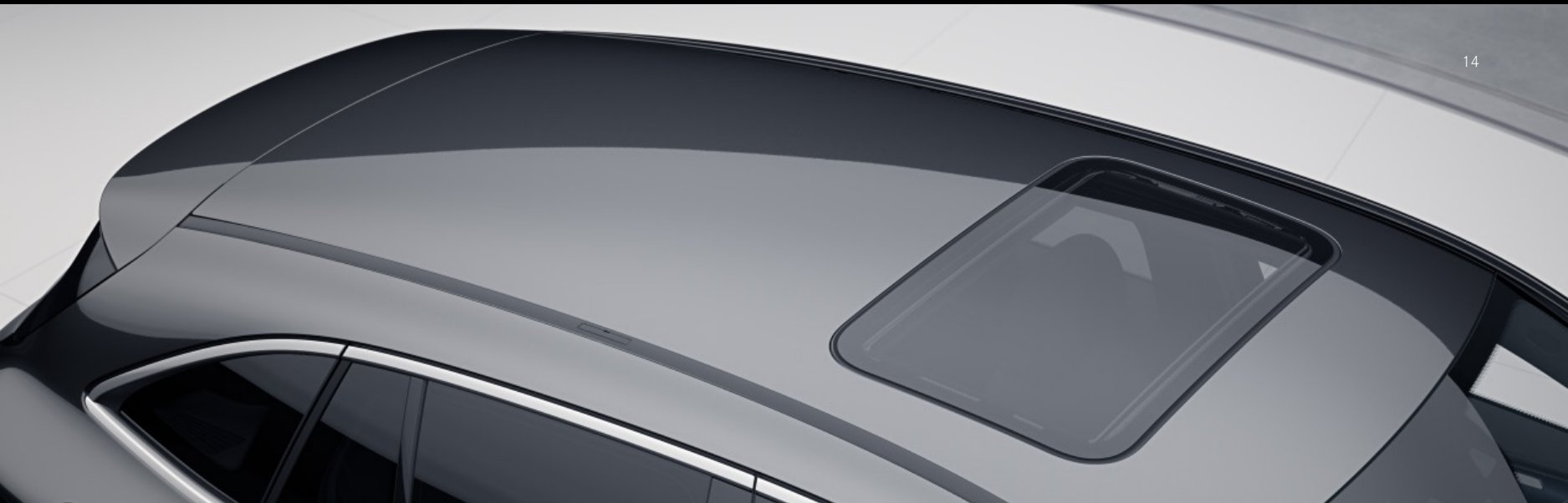

Electric sliding sunroof



Burmester® surround sound system



MBUX augmented reality for navigation



> Keep me updated



> Find a Retailer



> View the Range Guide

More comfort, more style, more EQC. You'll notice those bold 21" AMG multi-spoke alloys at once, while the electric sliding sunroof brightens the interior. Aside from the exceptional features standard on the AMG Line, this line also comes with the ENERGIZING package and the Parking package

with Active Parking Assist and 360° camera. For the perfect audio experience there's the Burmester® surround sound system, and the MBUX multimedia system provides augmented reality to help with navigation. And smartphone integration is also part of this exceptional EQC.

In addition/replacement to AMG Line:

Exterior

Parking package with Active Parking Assist and 360° camera

21" AMG multi-spoke alloy wheels

Electric sliding sunroof

Interior

ENERGIZING package

Communications and In-Car Entertainment

Burmester® surround sound system

MBUX augmented reality for navigation

Smartphone integration and wireless charging

Trim and Upholstery

Anthracite carbon fibre-look trim with high-gloss centre console

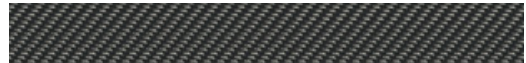

Leather – black



OTR from **£72,360** incl. VAT¹
Upgrade price from AMG Line **£4,645**

¹The recommended on-the-road price includes the Road Fund Licence applicable to the standard model plus delivery charge (£715.00 incl. VAT), new vehicle registration fee (£55.00) and number plates (£25.00 incl. VAT). VAT is calculated at the standard rate of 20%



> Keep me updated



> Find a Retailer



> View the Range Guide

AMG Line Premium Plus





> Keep me updated



> Find a Retailer



> View the Range Guide



Head-up display



Parking package with Active Parking Assist and 360° camera



Memory seats



> Keep me updated



> Find a Retailer



> View the Range Guide

Building on the high level of equipment of the AMG Premium line, this model also comes with a Memory package and a head-up display: a virtual colour

image showing information such as vehicle speed directly in the driver's field of vision.

In addition/replacement to AMG Line:

Exterior

Parking package with Active Parking Assist and 360° camera

Interior

Memory seats

Communications and In-Car Entertainment

Head-up display

Trim and Upholstery

Anthracite carbon fibre-look trim with high-gloss centre console

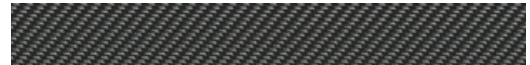

Leather - black



OTR from **£74,610** incl. VAT¹
Upgrade price from AMG Line **£6,895**

¹The recommended on-the-road price includes the Road Fund Licence applicable to the standard model plus delivery charge (£715.00 incl. VAT), new vehicle registration fee (£55.00) and number plates (£25.00 incl. VAT). VAT is calculated at the standard rate of 20%



> Keep me updated



> Find a Retailer



> View the Range Guide

Introducing MBUX



MBUX voice control



Multi-gesture touchpad control

Introducing MBUX, the new Mercedes-Benz User Experience infotainment system that can be controlled via voice and touch input. The new EQ is the latest model to feature this innovative way of communicating with your Mercedes-Benz.

MBUX (Mercedes-Benz User Experience) infotainment system comprises:

Voice control

- Activated by the keywords “Hey Mercedes”, the new intelligent voice control LINGUATRONIC¹ lets you control many of the infotainment functions, including destination input, phone calls or music selection
- MBUX is able to understand different accents and will adjust to you over time
- EQ-specific commands

Personalisation

- Turn the new EQ into your very own Mercedes-Benz by personalising driving modes, radio stations, ambient lighting and much more
- Your personal settings can be saved in up to seven different profiles, making your driving experience the best one possible
- Thanks to artificial intelligence, MBUX is able to learn and adapt over time. It will be able to predict your personal habits, such as navigation for frequently-driven routes, or the radio station you like to listen to on your way home from work

Touch inputs

- Beside voice control you can operate MBUX via touchscreen, the touchpad on the centre console, as well as touch control buttons on the steering wheel
- The touchpad recognises your handwriting should you wish to enter addresses or phone numbers silently

Maintenance and service

- Wondering when the next service is due? Or how much further you can drive until you need to recharge? Just ask your MBUX – it will tell you the answer

¹LINGUATRONIC off-board functions are currently only available for 3 years



> Keep me updated



> Find a Retailer



> View the Range Guide

Mercedes me connect.

Stay connected, any time, anywhere.

Mercedes me is a range of innovative online services designed to enhance your Mercedes-Benz experience. Accessible via mobile, tablet or PC, Mercedes me lets you enjoy the highest standards of care and support, in a way that integrates seamlessly with your busy lifestyle.



EQ Remote and Navigation Services (13U)

Ten years subscription standard with vehicle; further extension through Mercedes me store.



EQ-specific navigation that considers electrical range, topography and charging stations



Programming of charging settings and charging status



Programming of pre-entry climate control



For more information speak to your local Retailer or visit the Mercedes me connect store at shop.mercedes-benz.com/en-gb/connect



› Keep me updated



› Find a Retailer



› View the Range Guide

Mercedes me connect.

Stay connected, any time, anywhere.

Mercedes me is a range of innovative online services designed to enhance your Mercedes-Benz experience. Accessible via mobile, tablet or PC, Mercedes me lets you enjoy the highest standards of care and support, in a way that integrates seamlessly with your busy lifestyle.



Navigation Services (01U)

Three years standard with vehicle; further extension through Mercedes me store.
Visit the Mercedes me connect store or app for pricing.

Infotainment

Visit the Mercedes me connect store or app for pricing.



Live Traffic Information¹

Your navigation system receives traffic data in real time, enabling it to optimise the dynamic route guidance, minimising drive time and offering more precise estimation of arrival times.



Available parking spaces

Locates parking spaces for you in multi-storey car parks and on the street. Saving you time and hassle.



connect Store

In the Mercedes me connect Store you can purchase many digital services designed to make your everyday life easier and provide useful information relating to your networked vehicle.



TIDAL

Love music? Get a 12-month TIDAL HiFi subscription free with Mercedes me connect (worth £240) and unlock access to 58 million songs.



Local Search

This feature provides support in the local search for restaurants or hotels and much more.



Send2Car

Make your journey easier: set your destination using the Mercedes me app and send it directly to your car's navigation system.



Internet Radio

Listen to podcasts and radio stations from anywhere in the world.



Private Car sharing

Carsharing gives you the opportunity to share your vehicle in a straightforward and safe way with third parties who you authorise.

For more information speak to your local Retailer or visit the Mercedes me connect store at shop.mercedes-benz.com/en-gb/connect

¹Free of charge for first three years. Extension possible, visit the Mercedes me connect store for details on pricing



› Keep me updated



› Find a Retailer



› View the Range Guide

Mercedes me connect.

Stay connected, any time, anywhere.

Mercedes me is a range of innovative online services designed to enhance your Mercedes-Benz experience. Accessible via mobile, tablet or PC, Mercedes me lets you enjoy the highest standards of care and support, in a way that integrates seamlessly with your busy lifestyle.



Vehicle Set-up (08U)

Three years standard with vehicle; further extension through Mercedes me store. Visit the Mercedes me connect store or app for pricing.

Vehicle Monitoring (09U)

Three years standard with vehicle; further extension through Mercedes me store. Visit the Mercedes me connect store or app for pricing.



Remote Vehicle Status

Check safety information, such as coolant level and brake pad condition, so you can be sure your car is safe and ready to drive.



Personalisation

Store your preferences, such as your favourite radio stations and apps, to create your personal driver profile.



Parked Vehicle Locator

Forgot where you parked your car? No problem: you can locate and track your car, with the Parked Vehicle Locator.



Vehicle Tracker

Track the location of your car anywhere in the world.



Pre-Entry Climate Control

Programming of charging settings and Pre-Entry Climate Control for plug-in vehicles.



Remote Door Locking/Unlocking

Lock and unlock your car remotely, wherever you are in the world.

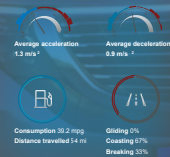

ECO Display

Monitor your driving style with ECO Display. It summarises your driving style from the start of the journey to its completion to help you achieve the most economical way to drive.



Geo-fencing

Set up a geographical boundary and receive alerts whenever your car enters or leaves this area.

For more information speak to your local Retailer or visit the Mercedes me connect store at shop.mercedes-benz.com/en-gb/connect



> Keep me updated



> Find a Retailer



> View the Range Guide

Charging your EQC at home – BP Chargemaster Homecharge

You can charge your EQC at home using a 7kW Homecharge unit in just 11 hours and 25 minutes¹



Just plug in overnight and it will be ready to go in the morning. Mercedes-Benz plug-in vehicle customers with off-street parking can benefit from the convenience and speed of charging at home by installing a Homecharge wallbox through our charging partner BP Chargemaster.

HOMECHARGE 7kW: **£899*** incl. VAT & installation

Key benefits of the 7kW BP Chargemaster Homecharge:

Robust and weatherproof, for indoor or outdoor use, and comes with a three-year warranty

Installed in as little as four weeks

As a Mercedes-Benz driver, when you install a Homecharge unit through BP Chargemaster you will automatically receive three months FREE plus membership to Polar, the UK's largest public charging network with over 7,000 charge points

Questions?

- Simply email mercedes-benz@bpchargemaster.com or call their dedicated Homecharge team on 01582 399 412

!Warning

If you are planning to charge your Mercedes-Benz plug-in electric vehicle using a 3-pin domestic plug socket you must get a qualified electrician to inspect and sign off the socket to confirm it is safe and suitable to charge your vehicle. Do not use an electric vehicle 3-pin charge cable with an extension cord.



¹Based on 7kW power output for electric vehicles, charge times are approximates only. Specified voltage and current values refer to network infrastructure and can be limited by the vehicle. Times are from 10-100% charge using a wallbox (three-phase) or standard socket (single-phase)

*Price correct at time of publication, subject to change. For full BP Chargemaster Homecharge Terms & Conditions visit <https://bpchargemaster.com/terms-and-conditions-of-sale-olev/>



> Keep me updated



> Find a Retailer



> View the Range Guide

Model prices

	Model line	CO ₂ ¹	Basic RRP excl. VAT (£)	Total RRP incl. VAT (£)	Road Fund Licence (£) ²	Rec. OTR price (£) ^{3,4}	P11D value (£)	BiK tax rate 2019/20 (%)
EQC 400 Battery electric vehicle, 408 hp/300 kW Electric range 232-259 miles - WLTP ¹	EQC Sport	0	54,104.17	64,925.00	0.00	65,720.00	65,665.00	16
	EQC AMG Line	0	55,766.67	66,920.00	0.00	67,715.00	67,660.00	16
	EQC AMG Line Premium	0	59,637.50	71,565.00	0.00	72,360.00	72,305.00	16
	EQC AMG Line Premium Plus	0	61,512.50	73,815.00	0.00	74,610.00	74,555.00	16

¹The indicated values were determined according to the prescribed measurement method - Worldwide Harmonised Light Vehicle Test Procedure (WLTP). Figures shown may include options which are not available in the UK.

For Battery Electric Vehicles (BEV), figures are determined with battery fully charged. These models require mains electricity for charging.

Figures shown are for comparability purposes; only compare with other cars tested to the same technical procedures. Figures may not reflect real life driving results, which will depend upon a number of factors including the starting charge of the battery, factory-fitted options, accessories fitted (post registration), variations in weather, driving styles and vehicle load. Further information about the test used to establish fuel consumption and CO₂ figures can be found at <http://www.mercedes-benz.co.uk/WLTP>

²A different first year rate of Vehicle Excise Duty (Road Fund Licence) applies for new cars. Please refer to page 40 for the relevant rate for the second and subsequent years

³The recommended on-the-road price includes the Road Fund Licence applicable to the standard model plus delivery charge (£715.00 incl. VAT), new vehicle registration fee (£55.00) and number plates (£25.00 incl. VAT). VAT is calculated at the standard rate of 20%

⁴The EQC currently qualifies for the Government's Plug-In Car Grant which can be deducted from the above recommended OTR price. This grant is provided by the UK Government's Office for Low Emission Vehicles (OLEV) and as such, is subject to change or removal in future depending on Government policy



> Keep me updated



> Find a Retailer



> View the Range Guide

Driving Assistance Plus package

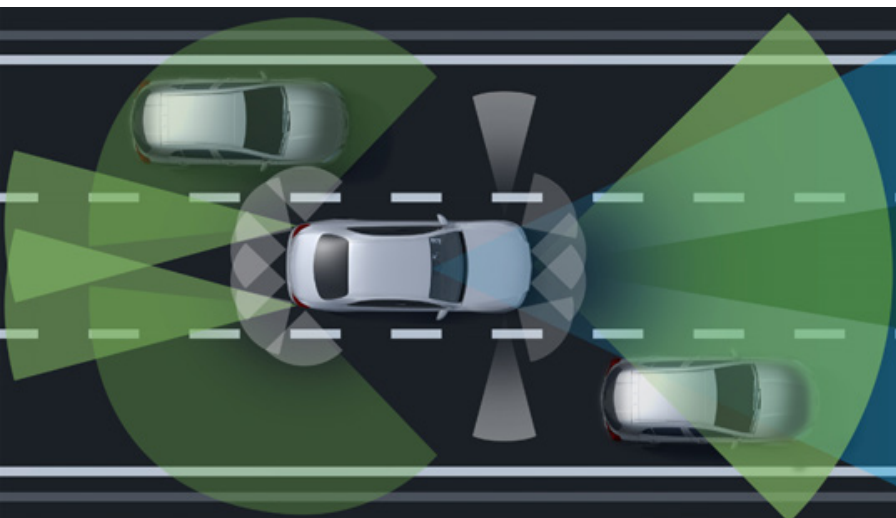

Active Blind Spot Assist



Active Braking Assist

The Driving Assistance Plus package contains highly intelligent features to help you stay safe on the road – by making the drive more effortless, by warning of danger, and by taking steps to protect you in an emergency.

Driving Assistance Plus package (code 23P) – designed and priced as a package, including items listed below.

AMG Line, AMG Line Premium, AMG Line Premium Plus equipment lines
Total incl. VAT £1,695.00

Driving Assistance Plus package comprises:

Active Blind Spot Assist

Exit warning function

Active Braking Assist

Cornering and cross-traffic function; congestion/emergency braking function

Active Distance Assist DISTRONIC

Active Speed Limit Assist
Extended restart function on motorways
Route-Based Speed Adjustment with end-of-tailback function

Active Lane Keeping Assist

Active Steering Assist

Active Lane Changing Assist
Active Emergency Stop Assist with SOS function
Emergency lane function

Evasive Steering Assist

Pedestrian warning function near pedestrian crossings

PRE-SAFE® PLUS



> Keep me updated



> Find a Retailer



> View the Range Guide

Colours and materials



Some of the model features, optional extras and colours shown may not be available, or may only be available in a different specification.



> Keep me updated



> Find a Retailer



> View the Range Guide

Colours and materials

27

Non-metallic and metallic paints

Total prices incl. VAT



149 polar white **standard**

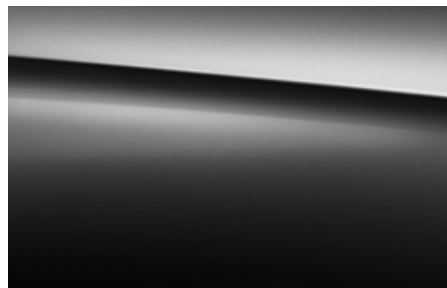

197 obsidian black **£685.00**



896 brilliant blue¹ **£685.00**

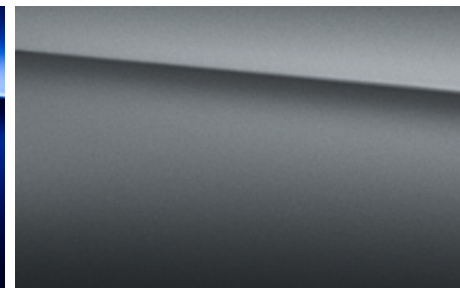

297 designo selenite grey magno² **£1,795.00**



831 graphite grey **£685.00**



922 high-tech silver **£685.00**



799 designo diamond white bright **£895.00**

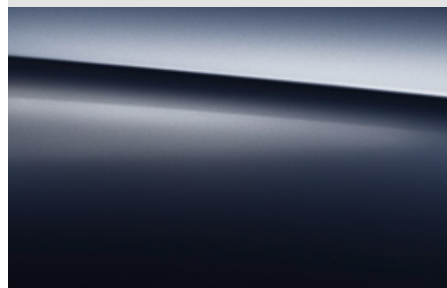

890 cavansite blue **£685.00**



996 designo hyacinth red¹ **£895.00**

¹Not available on Sport ²designo magno matt paint finishes require extra care. Please refer to the Owner's Manual for instructions Please note that, owing to limitations of on-screen representation, paint colours may differ from those shown



> Keep me updated



> Find a Retailer



> View the Range Guide

Trim



H66 aluminium trim with high-gloss black centre console

Sport	●
AMG Line	-
AMG Line Premium	-
AMG Line Premium Plus	-



H65 anthracite carbon fibre-look trim with high-gloss black centre console

Sport	-
AMG Line	●
AMG Line Premium	●
AMG Line Premium Plus	●



736 black open-pore ash wood trim with high-gloss black centre console

Sport	-
AMG Line	-
AMG Line Premium	-
AMG Line Premium Plus	-



> Keep me updated



> Find a Retailer



> View the Range Guide

Upholstery



111A ARTICO man-made leather – black

Sport	●
AMG Line	–
AMG Line Premium	–
AMG Line Premium Plus	–



115A ARTICO man-made leather – silk beige/black

Sport	●
AMG Line	–
AMG Line Premium	–
AMG Line Premium Plus	–



251A Leather¹ – black

Sport	–
AMG Line	●
AMG Line Premium	●
AMG Line Premium Plus	●

¹At least 80% of the seat upholstery is pure leather, while up to 20% may consist of man-made leather



> Keep me updated



> Find a Retailer



> View the Range Guide

Wheels



R90 19" alloy wheels (4) – 5-twin-spoke design, painted black with a high-shine finish
235/55 R 19 tyres

Sport	●
AMG Line	-
AMG Line Premium	-
AMG Line Premium Plus	-



RRR 20" alloy wheels (4) – multi-spoke aero design, painted black with a high-shine finish
front: 235/55 R 20 tyres; rear 255/45 R 20 tyres

Sport	-
AMG Line	●
AMG Line Premium	-
AMG Line Premium Plus	-



> Keep me updated



> Find a Retailer



> View the Range Guide



RWI 21" AMG alloy wheels (4) – multispoke design, painted black with a high-shine finish
front: 235/45 R21 tyres; rear 255/40 R21 tyres

Sport	-
AMG Line	-
AMG Line Premium	●
AMG Line Premium Plus	●



Standard equipment

Item	EQC Sport	EQC AMG Line	EQC AMG Line Premium	EQC AMG Line Premium Plus
Battery and Charging				
80 kWh battery	●	●	●	●
CCS-2 connector (Combined Charging System, compatible with AC and DC)	●	●	●	●
7.4 kW on-board charger	●	●	●	●
110 kW DC on-board charger	●	●	●	●
Charging cable for wallbox and public charging stations, Type 2 (Mode 3) - 4 m	●	●	●	●
IONITY - 1 year Rapid charging with IONITY	●	●	●	●
Engine, Transmission and Suspension				
4MATIC all-wheel drive	●	●	●	●
Exterior				
Mirror package Automatically-dimming interior and exterior driver's mirrors Electrically-folding exterior mirrors	●	●	●	●
Aluminium running boards	-	●	●	●
Heat- and noise-insulating acoustic glass	●	●	●	●
Privacy glass	●	●	●	●
Sliding sunroof	-	-	●	●
Summer tyres	●	●	●	●

● Standard - Not available

Item	EQC Sport	EQC AMG Line	EQC AMG Line Premium	EQC AMG Line Premium Plus
Interior				
ENERGIZING package Intelligent cross-linking of all comfort systems. Drivers can choose from expert-configured programs for activation and relaxation, depending on their personal needs	-	-	●	●
Interior light package	●	●	●	●
Memory package	-	-	-	●
Seat Comfort package Electric backrest and height adjustment Electric seat cushion inclination adjustment Electropneumatic four-way lumbar support Manual seat cushion depth adjustment by 6 cm	●	●	●	-
Stowage package 12 V socket left of the luggage compartment Collapsible crate under load compartment floor Map pockets on backs of the front seats Stowage compartment under load compartment floor (lockable) Twin USB charging ports in the rear (type C)	●	●	●	●
12 V socket in the load area	●	●	●	●
Ambient lighting 64 colours, Colour changing based on temperature setting Dynamic mode: atmospheric colour changes thanks to slow, stepless transition between different colours When plugging in the charging cable, each state of charge is visualised for approx. 30 seconds, similar to the LED in the charging socket: establishing connection (pulsating yellow), ready to charge (continuous yellow), battery is being charged (pulsating green), battery full (continuous green)	●	●	●	●



> Keep me updated



> Find a Retailer



> View the Range Guide

Standard equipment

33

Item	EQC Sport	EQC AMG Line	EQC AMG Line Premium	EQC AMG Line Premium Plus
Interior (continued)				
Floor mats	●	-	-	-
Floor mats – AMG	-	●	●	●
Heated front seats	●	●	●	●
Split-fold rear seats – 40:20:40	●	●	●	●
Paint, Trim and Upholstery				
Dashboard – leather-look	●	●	●	●
Paint – non-metallic	●	●	●	●
Roof lining – black fabric	●	●	●	●
Trim – aluminium with high-gloss centre console	●	-	-	-
Trim – anthracite carbon fibre-look trim with high-gloss centre console	-	●	●	●
Upholstery – ARTICO man-made leather	●	-	-	-
Upholstery – leather	-	●	●	●
Safety and Assistance Systems				
Anti-Theft Protection package	●	●	●	●
KEYLESS-GO Comfort package	●	●	●	●
Convenience opening and closing				
Door handles with chrome inserts				
Hands-free access				
KEYLESS-GO access and drive authorisation system				
Vehicle key with KEYLESS-GO functionality				

Item	EQC Sport	EQC AMG Line	EQC AMG Line Premium	EQC AMG Line Premium Plus
KEYLESS-GO Comfort package	●	●	●	●
Convenience opening and closing				
Door handles with chrome inserts				
Hands-free access				
KEYLESS-GO access and drive authorisation system				
Vehicle key with KEYLESS-GO functionality				
Parking package with Active Parking Assist and 360° camera	-	-	●	●
Parking package with Active Parking Assist and rear camera	●	●	●	●
Active Brake Assist	●	●	●	●
Active Lane Departure Warning	●	●	●	●
Blind Spot Assist	●	●	●	●
Cruise control	●	●	●	●
EASY-PACK tailgate	●	●	●	●
Head-up display	-	-	-	●
Multibeam LED headlights	●	●	●	●
Adaptive Highbeam Assist Plus (anti-dazzle continuous high beam)				
Cornering light function or cornering light function with roundabout and cross-traffic functions. City light, country road light and motorway light modes				
DYNAMIC SELECT	●	●	●	●
Four different drive programs: Max Range, Eco, Comfort and Sport				
Five recuperation levels: D Auto (Eco Assist, standard setting); D+ (coasting); D (low recuperation); D- (medium recuperation); D- - (high recuperation)				
Tirefit	●	●	●	●

● Standard - Not available



> Keep me updated



> Find a Retailer



> View the Range Guide

Standard equipment

Item	EQC Sport	EQC AMG Line	EQC AMG Line Premium	EQC AMG Line Premium Plus
Communications and In-Car Entertainment				
Augmented reality navigation	-	-	●	●
Burmester® surround sound system 9-channel DSP amplifier with a total output power of 590 W (7 × 50 watts and 2 × 120 watts) for maximum sound quality with high volume reserves 13 high-performance speakers precisely tailored to the vehicle interior to ensure well-balanced and dynamic music reproduction Frontbass technology with woofers integrated into the body shell for vibrant bass reproduction Multichannel support for true surround sound Noise compensation Sound optimisation for front and rear seats Sound preset: surround function to generate virtual surround sound	-	-	●	●
Digital radio	●	●	●	●
EQ navigation services Navigation optimised for Mercedes-Benz EQ Display of charging stations (info on availability) Range on map (range display) Programming of charging settings and pre-entry climate control, including remote retrieval of charging status and range	●	●	●	●
Hard disk navigation	●	●	●	●
Live traffic information – 3 years	●	●	●	●

Item	EQC Sport	EQC AMG Line	EQC AMG Line Premium	EQC AMG Line Premium Plus
MBUX multimedia system with 10.25-inch instrument display and 10.25-inch media display with touchscreen	●	●	●	●
Mercedes-Benz sound system 1 centre speaker 2 Frontbass speakers 2 tweeters 4 mid-range speakers 225 W amplifier output	●	●	-	-
Smartphone integration	-	-	●	●
Wireless smartphone charging	-	-	●	●
Service				
Vehicle Monitoring (09U) ECO display Parked vehicle locator Geo-fencing Vehicle tracker	●	●	●	●
Vehicle Set-up (08U) Preferences: store your personal driver profile Pre-entry climate control: programming of auxiliary heating/ventilation Remote door locking and unlocking Remote retrieval of vehicle status	●	●	●	●



Optional equipment

Item	Notes		EOC Sport	EOC AMG Line	EOC AMG Line Premium	EOC AMG Line Premium Plus	Basic RRP excl. VAT (£)	Total RRP incl. VAT (£)
Exterior								
Tow bar		550	○	-	-	-	625.00	750.00
Paint, Trim and Upholstery								
Metallic paint		-	○	○	○	○	570.83	685.00
designo diamond white metallic	Please check with your Retailer for availability	996,799	○	○	○	○	745.83	895.00
designo hyacinth red metallic	Please check with your Retailer for availability	996,799	○	○	○	○	745.83	895.00
designo selenite grey magno	designo magno matt paint finishes require extra care. Please refer to the Owner's Manual for instructions. Please check with your Retailer for availability	297	○	○	○	○	1,495.83	1,795.00
Upholstery – ARTICO man-made leather (silk beige/black)		115A	○	-	-	-	no-cost option	



Technical data

	Engine	
Model	EQC 400 4MATIC	
Engine		
Battery type	lithium-ion high-voltage	
Electric motor type	asynchronous	
Battery capacity	kWh	80
Power ¹	hp (kW)	408 (300)
Torque ¹	Nm	760
On-board charger	kW	7.4
Transmission		
Single-speed automatic	●	

	Engine	
Model	EQC 400 4MATIC	
Performance		
		auto.
Acceleration 0-62 mph	sec	5.1
Top speed	mph	112
Charging time – AC outlet (230 V/13 A) 10-100% ^{2,3} Wallbox (400 V/16 A) 10-100% ² Public rapid charging (110 kW) 10-80% ⁴	hr	40.75
	hr	11.0
	min	40
Power consumption combined	Wh/km	250-224
Electric range – WLTP ⁴	m	232-259
Emissions standard		EU6
CO ₂ emissions	g/km	0
Fuel consumption^{5,6,7}		
		auto.
Combined (consumption dependent on chosen optional equipment)	l/100 km	0.0
	mpg	0.0

● Standard ¹Figures according to Regulation (EC) No. 595/2009 in the currently applicable version

²Specified voltage and current values refer to network infrastructure and can be limited by the vehicle. Times are from 10-100% charge using a wallbox (three-phase) or standard socket (single-phase)

³**If you are planning to charge your Mercedes-Benz plug-in electric vehicle using a 3-pin domestic plug socket you must get a qualified electrician to inspect and sign off the socket to confirm it is safe and suitable to charge your vehicle.**

Do not use an electric vehicle 3-pin charge cable with an extension cord

⁴Specified voltage and current values refer to network infrastructure and can be limited by the vehicle. Times are from 10-80% charge using public rapid charging at 110 kW

⁵The indicated values were determined according to the prescribed measurement method – Worldwide Harmonised Light Vehicle Test Procedure (WLTP). Figures shown may include options which are not available in the UK. For Battery Electric Vehicles (BEV) figures determined with battery fully charged. These models require mains electricity for charging. Figures shown are for comparability purposes; only compare with other cars tested to the same technical procedures. Figures may not reflect real life driving results, which will depend upon a number of factors including the starting charge of the battery, factory-fitted options, accessories fitted (post registration), variations in weather, driving styles and vehicle load. Further information about the test used to establish fuel consumption and CO₂ figures can be found at <http://www.mercedes-benz.co.uk/WLTP>

⁶All figures are based on a standard specification with the smallest tyre size ⁷The choice of wheels and transmission may affect CO₂ emissions and corresponding Road Fund Licence



> Keep me updated



> Find a Retailer



> View the Range Guide

Model	Engine	
	EQC 400 4MATIC	
Weights and capacities	auto.	
Kerb weight	kg	2,495
Perm. Gross Vehicle Weight	kg	2,940
Boot capacity ⁷ - seats down/up	l	1,060/500
Towing capacity - unbraked/braked	kg	750/1,800
Turning circle	m	11.80

Model	Engine	
	EQC 400 4MATIC	
Insurance	auto.	
Group rating	tba	
Insurance ratings may vary depending on model line and specification. Please refer to http://www.thatcham.org/abigrouprating/ for further details		

⁷Figures according to Directive 70/156/EEC as amended by 2000/40/EC



> Keep me updated



> Find a Retailer



> View the Range Guide

EQC 400 Sport

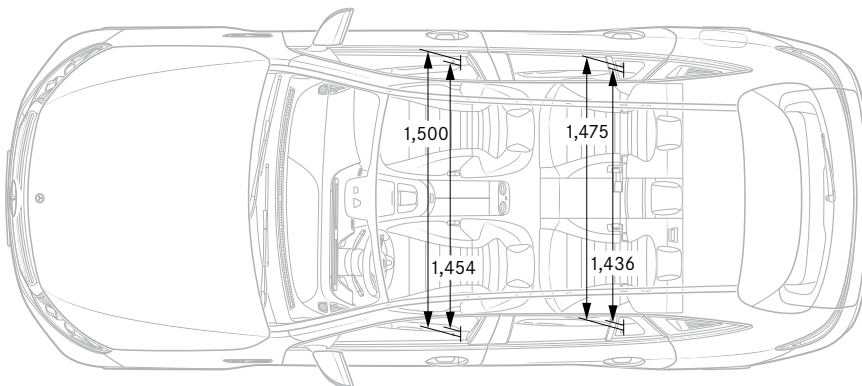
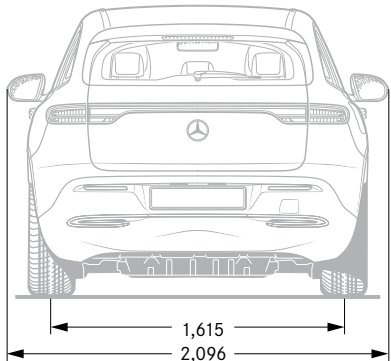
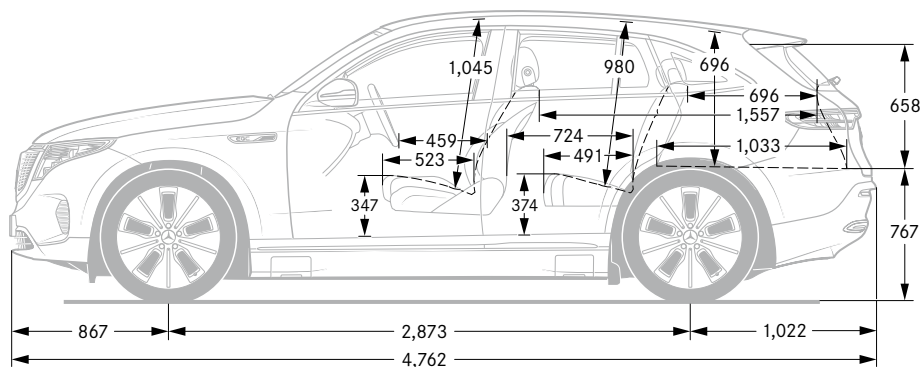
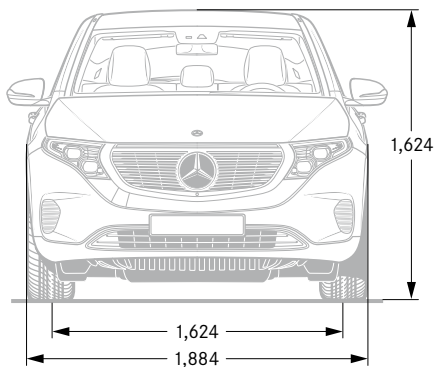

All measurements in millimetres. The dimensions shown are mean values and apply to standard-specification, unladen vehicles



> Keep me updated



> Find a Retailer



> View the Range Guide

EQC 400 AMG Line

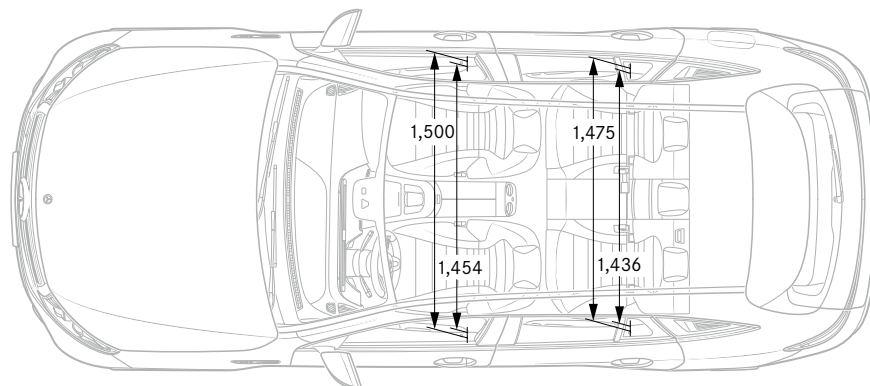
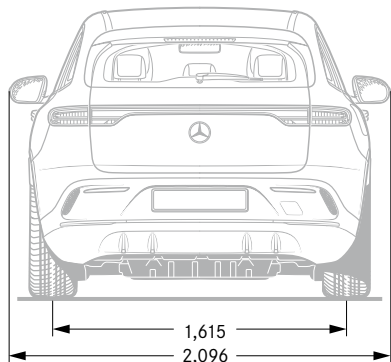
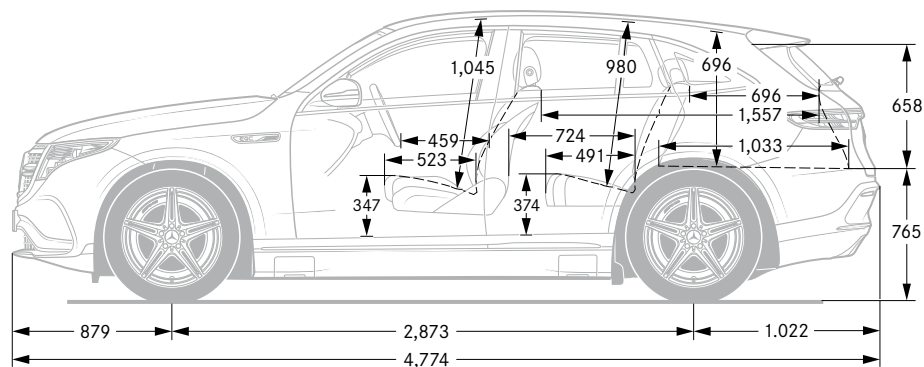
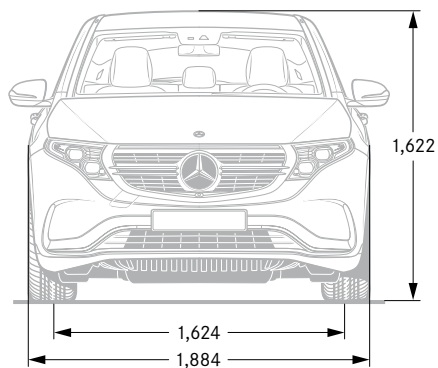

All measurements in millimetres. The dimensions shown are mean values and apply to standard-specification, unladen vehicles. The figures on pages 36-39 are correct at time of publication. Please refer to the government website for latest data - <http://carfueldata.direct.gov.uk/>



Road Fund Licence



All road vehicle registrations are subject to Vehicle Excise Duty (Road Fund Licence), which varies in accordance with the vehicle's CO₂ emissions. A first year rate for each taxation band will apply. The table below shows the bands (A–M) created by the DVLA and the corresponding Road Fund Licence. CO₂ emissions are listed in the technical data on page 36, and the relevant Excise Duty is reflected in the on-the-road prices on page 24.

Band	CO ₂ emissions (g/km)	First year rate petrol (£)	First year rate diesel (£) ¹	First year rate alt. fuel (£)	Standard rate (£)	Premium rate (£) ²
A	0	0.00	0.00	0.00	0.00	310.00
B	1 to 50	10.00	25.00	0.00	140.00	450.00
C	51 to 75	25.00	110.00	15.00	140.00	450.00
D	76 to 90	110.00	130.00	100.00	140.00	450.00
E	91 to 100	130.00	150.00	120.00	140.00	450.00
F	101 to 110	150.00	170.00	140.00	140.00	450.00
G	111 to 130	170.00	210.00	180.00	140.00	450.00
H	131 to 150	210.00	530.00	200.00	140.00	450.00
I	151 to 170	530.00	855.00	520.00	140.00	450.00
J	171 to 190	855.00	1,280.00	845.00	140.00	450.00
K	191 to 225	1,280.00	1,815.00	1,270.00	140.00	450.00
L	226 to 255	1,815.00	2,135.00	1,805.00	140.00	450.00
M	over 255	2,135.00	2,135.00	2,125.00	140.00	450.00

¹Applies to all Mercedes-Benz diesel models which do not comply with Real Driving Emissions step 2 (RDE2)

²Premium rate only applicable to vehicles where the list price is over £40,000 including any factory-fitted options, standard UK delivery charge, number plates, fuel and VAT



› Keep me updated



› Find a Retailer



› View the Range Guide

Services and insurance

Mercedes-Benz ServiceCare

We believe that servicing costs should be as flexible and affordable as possible for your EQC, which is why we offer ServiceCare.

ServiceCare is an easy way to budget for all your servicing costs. It spreads your bills into manageable payments based on whether you have a new or used Mercedes-Benz.

With ServiceCare we guarantee the price of parts and labour for up to four services and safeguard against any further inflation. It also covers the cost of all recommended service items including brake fluid, air filters, fuel filters and screen wash.

You can choose either to add your servicing costs into your monthly spend at £22 per month, or pay the full amount in a one-off payment, giving you peace of mind that they are taken care of for the period of the plan.

To receive a personalised ServiceCare plan recommendation visit the ServiceCare Calculator at servicecarerates.mercedes-benz.co.uk

Warranty and breakdown cover

Every Mercedes-Benz comes with a three-year unlimited mileage warranty against manufacturing or material defects¹ and up to 30 years warranty against perforation due to corrosion from the inside out.² What's more, it's also covered by Mercedes-Benz Roadside Assistance – a unique package comprising up to 30 years pan-European breakdown assistance.²

Battery Warranty

The battery comes with an eight-year 100,000-mile warranty.

Motor Insurance

Superb cover comes as standard. When reviewed by an independent research company, Defaqto, Mercedes-Benz Motor Insurance received a five-star rating, the highest rating available. We design our Motor Insurance specifically for Mercedes-Benz drivers.

For more information or to obtain a quote, click [here](#).

¹Applies to vehicles sold by Mercedes-Benz in the UK to its franchised Retailers ²Subject to full Terms and Conditions, dependent on date of registration, available upon request Mercedes-Benz Motor Insurance is underwritten by Aviva Insurance UK Limited. Credit provided, subject to status, by Mercedes-Benz Financial Services UK Ltd, MK15 8BA *For joint protection, calls may be recorded and/or monitored. All calls charged at local rate. We may decline to quote in some circumstances



> Keep me updated



> Find a Retailer



> View the Range Guide

Mercedes-Benz Finance

Why should you finance with Mercedes-Benz?

At Mercedes-Benz we believe a great driving experience should be matched by an equally great ownership experience. That is why we put just as much thought, time and effort into designing our finance options, our service plans and our insurance cover as we do into our vehicles.

We are not in the business of simply providing a loan to fund the purchase of your dream vehicle. We look on it as a journey that we take with you, from the moment you choose your new Mercedes-Benz, to helping you in choosing your next one.

If you would like to find out more about any of our current offers, simply call into your local Mercedes-Benz Retailer where one of our Business Managers will be more than happy to talk you through anything you need to know.

Helping you find the right solution.

You should find our finance packages are more convenient than a traditional personal loan because:

- Funds are immediately available – no waiting for cheques or loans to clear.
- There is no security required – either against your home or other assets.
- We have clear and transparent rates – the APR we quote is the APR you get.
- We have friendly Business Managers – experts in vehicle finance who can talk you through all of your plans in detail.

We also offer Contract Hire, Operating Lease and Hire Purchase solutions. If you would like to find out more about these speak to your Retailer or visit www.mercedes-benz.co.uk/fandi



> Keep me updated





> Find a Retailer



> View the Range Guide

Follow us on the following social media channels:

 facebook.com/mercedesbenzuk

 twitter.com/mercedesbenzuk

 youtube.com/mercedesbenzuk

 instagram.com/mercedesbenzuk

Effective from December 2019 Production. Information correct at time of publication.

Prices and specifications are subject to change without prior notice.

MBN293PL/1019 MY800.5

Mercedes-Benz Cars UK Limited, Tongwell, Milton Keynes, MK15 8BA. Company number 2448457 www.mercedes-benz.co.uk